



**OPERATOR'S MANUAL**

for

*Chris-Craft*

**MARINE ENGINES**

**MODEL "431" V-8 ENGINE**

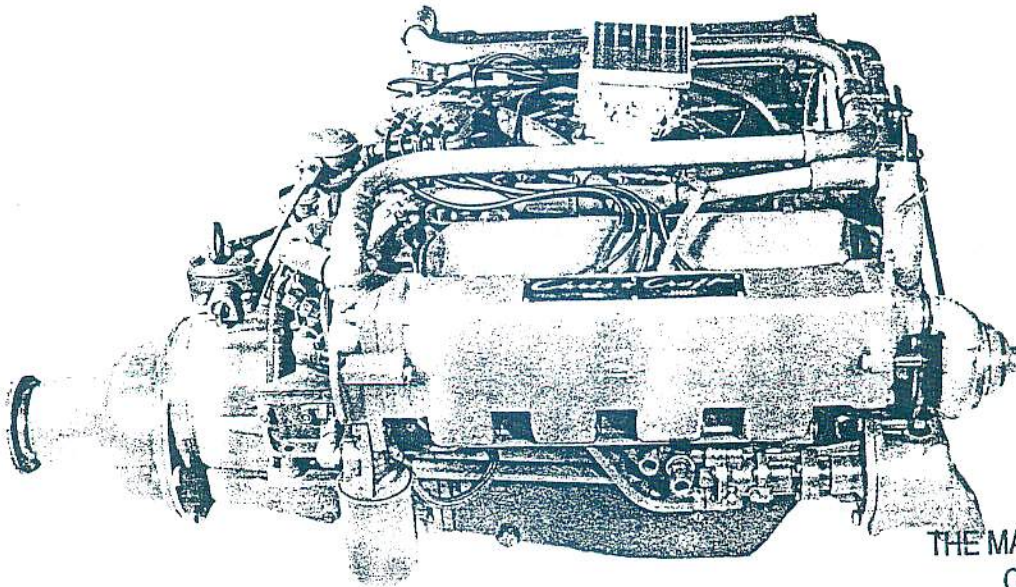

THE MARINERS' MUSEUM  
CHRIS CRAFT  
NEWPORT NEWS, VA. 23606

## TO ORDER PARTS

ENGINE MODEL and ENGINE SERIAL NUMBER must be furnished when replacement parts are required.

The model designation (\*) and serial number (\*) will be found stamped into a plate fastened on top of the exhaust manifold.

### ILLUSTRATION OF ENGINE PLATE

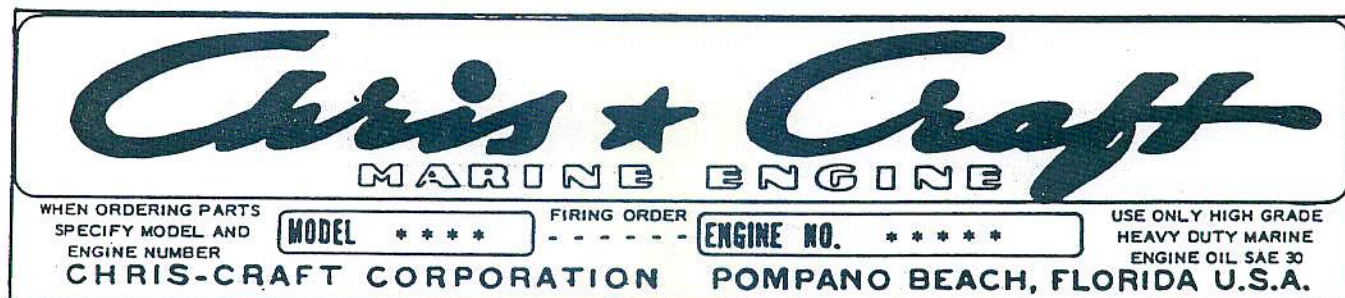

Order parts from your nearest Chris-Craft dealer or direct from Chris-Craft Corporation, Service Parts Department, Algonac, Michigan being sure to furnish numbers mentioned above.

For the best performance from your engine-  
INSIST ON GENUINE CHRIS-CRAFT PARTS.



## GENERAL ENGINE SPECIFICATIONS

Type	4 Cycle, Valve-in-Head, V-8
Bore	4.30 inches
Stroke	3.70 inches
Piston Displacement	430 cubic inches
Horsepower	275 at 4000 RPM
Maximum Torque	396.4 ft. lbs. at 2900 RPM
Nominal Compression Ratio	8.0:1 (By Volume)
Minimum Recommended Idle Speed	500 RPM
Oil Pressure	18 lbs. at Idle (Approximate) 35 to 45 lbs. Maximum Speed (hot)
Oil Pan Capacity	Approximately 8 to 9 qts. Capacity will vary with running angle.
Reverse Gear Oil Capacity	Separate System Direct Drive - Approximately 2 qts. Reduction Drive - Approximately 3 qts.
Carburetion	Single four-barrel downdraft carburetor.

## TABLE OF CONTENTS

YOUR NEW CHRIS-CRAFT MARINE ENGINE _____	3
Identification	3
Use Genuine Factory Replacement Parts	3
Break-In	3
To Start Engine	3
 LUBRICATION _____	 4
Oil Pressure	4
Oil Recommendation	4
To Change Oil	4
Oil Filter	5
 ELECTRICAL SYSTEM _____	 5
Ignition Timing	5
Ignition Circuit	5
Battery	6
Alternator & Voltage Regulator	6
Starting Motor	7
 FUEL SYSTEM _____	 7
Fuel Recommendation	7
Carburetor	7
Fuel Pump	7
 COOLING SYSTEM _____	 7
Operation	7, 8, 9
Water Temperature	9
Maintenance	9
 VALVES & VALVE TAPPETS _____	 10
 REVERSE GEAR _____	 10
Paragon Hydraulic	10, 11
 ANNUAL LAY-UP _____	 12
 ANNUAL FITTING OUT _____	 13
 MAINTENANCE SCHEDULE _____	 13
 ENGINE INSTALLATION RECOMMENDATIONS _____	 14
Mounting	14
Alignment	15
Exhaust	15
Recommended Exhaust Sizes	15
Cooling Water Intake	15
Engine Controls	15
Instruments	16
 INFORMATION AVAILABLE _____	 16
 ROTATION DIAGRAM _____	 16
 WIRING DIAGRAM _____	 17
 MAJOR PARTS OF CHRIS-CRAFT V-8 ENGINE DIAGRAM _____	 18

## YOUR NEW CHRIS-CRAFT MARINE ENGINE

Your Chris-Craft Marine Engine has been delivered to you after a great deal of skillful engineering, careful manufacture, and exhaustive testing. Chris-Craft's years of practical experience in the marine field are packed into every engine leaving our plant. With reasonable care during operation and a minimum amount of maintenance, this engine will deliver a maximum amount of dependable, economical performance and long life.

### IDENTIFICATION

On every engine there is a plate on top of the manifold giving the model and serial number. This information is important and should be included in all parts orders and correspondence relating to the engine.

### USE GENUINE FACTORY REPLACEMENT PARTS

All Chris-Craft Marine Engines have special parts designed to give the best performance under conditions found only in marine use. To insure long life and dependable performance, we strongly recommend that only factory replacement parts be used. These may be obtained from your nearby Chris-Craft Dealer. Internal engine parts of other manufacture are plainly marked in the parts lists and these parts may be obtained from the manufacturer and his distributors.

### BREAK-IN

It is very important that the engine be broken in properly. All moving parts in the engine are new and have only been run for a few hours while the engine had it's final test. Engines must be run carefully in the beginning until all parts are worn in and the engine becomes limber. Only then will it be safe to run the engine fast for sustained periods of time.

Running new engines or engines after a major overhaul at excessively low RPM for long periods should be avoided because it will tend to prolong the break-in period and delay proper seating of piston rings.

During the first ten hours operation, do not exceed 2500 RPM. During the second ten hours operation, do not exceed 3200 RPM. We do not recommend a continuous speed in excess of 3600 RPM. Use in excess of 4000 RPM voids factory warranty. An abnormal rise in engine temperature will indicate that the engine is being run a little too fast.

During the entire life of the engine, always run the engine at medium speeds to allow the oil to warm up before running at sustained high speeds. When coming to the dock after a run always allow the engine to run at moderate speed for three to five minutes before turning off the ignition. This can be done by slowing down several hundred yards before you get to the dock and coming in slow or letting the engine idle after you have come into the dock. This is to allow the valves to cool down while the water is still circulating in the engine. This will help prevent warped valves.

### TO START ENGINE

Before starting the new engine, check the oil level in the crankcase, check fuel in tank and ventilate engine compartment thoroughly. Shift the reverse gear to neutral position. Open the throttle slightly (approximately 1/8 open.)

With ignition key, turn on switch and engage the starter. Do not engage the starter for prolonged periods. If the engine does not start immediately, investigate the cause of trouble. As soon as the engine starts, release the starter. Check to make sure that oil pressure is present and that cooling water is circulating.

This engine is equipped with an automatic choke. If the engine does not start due to flooding, the throttle should be opened fully which will reduce the choking action. The starter should be engaged with throttle opened fully. As soon as engine starts close the throttle.

Before engaging or disengaging the reverse gear it is advisable to slow the engine down to 1000 RPM or less. Shifting at higher RPM will shorten the life of the reverse gear and may cause damage.

## LUBRICATION SYSTEM

### OIL PRESSURE

Form the habit of watching the oil pressure gauge. Advance notice of serious trouble is nearly always indicated by the oil gauge

Oil pressure should be approximately 18 lbs. at idle speed and 35 to 45 lbs at maximum speed with the engine hot.

### ENGINE OIL RECOMMENDATION

Chris-Craft Marine Engines should be serviced with oil of good quality to insure smooth operation, freedom from trouble and best engine performance obtainable. A Marine Engine works at maximum capacity 90% of the time while an automobile engine rarely works at it's maximum even 10 - 15 percent of the time. Therefore, the requirements for a good lubricating oil are far greater in a Marine Engine.

We recommend the use of S. A. E. #30 lubricating oil containing detergents and additives conforming to API designation "MS" or "DG", U. S. Military Spec. MIL-L-2104-A (or supplement #1) or I. C. E. I. designation "A" or "B". It is not recommended that different brands of oil be mixed. Always replenish with the same make and type of oil that is in the crankcase. If it is necessary to change the make of oil, always drain the crankcase as completely as possible before refilling

### TO CHANGE OIL

The new engine, when shipped, is filled with special break-in oil. After fifteen to twenty hours of running, replace with S. A. E. 30 motor oil and also replace the filter element. Subsequent oil changes should be made every fifty to one hundred hours, depending on the type of service to which the engine is subjected. An engine used for short runs only, will require an oil change more often than an engine used for long runs. During the longer run, the oil attains the proper operating temperature, thereby reducing the possibility of contamination.

The best method for removing crankcase oil is with a suction pump. The easiest method is to insert the suction hose through the dip-stick tube. Most marine service stations are equipped with special pumps for removing oil, or a suitable pump may be purchased from your Chris-Craft Dealer.

Direct and reduction drive Model "431" engines hold approximately eight or nine quarts of oil. The amount of oil will vary since engines are installed at different angles in different boat models.

Hydraulic Reverse Gears have an oil supply that is separate from the engine oil supply and therefore require individual checking and replacing. We recommend the use of Type "A" Hydraulic Transmission Fluid, which should be changed in the new engine when the break-in oil is removed after fifteen to twenty hours running and thereafter every 100 hours or once each season, whichever comes first.

### OIL FILTER

The oil filter element should be replaced in the new engine when the break-in oil is removed after fifteen to twenty hours running. Thereafter, replace the oil filter element every 100 running hours.

If oil pressure fluctuates due to a clogged oil filter, reduce speed and change the oil-filter element immediately. This is a full flow filter which can restrict oil flow if clogged with dirt even though an oil bypass is incorporated in its design.

### ELECTRICAL SYSTEM

The model "431" engine uses a 12 volt electrical system. The starter, alternator, regulator, distributor and coil all have name plates affixed denoting the respective manufacturer. These units are guaranteed and serviced by these manufacturers. Apply directly to the manufacturer's distributor or dealer for warranty or service on these units.

It is important that all electrical connections be periodically inspected to make certain that the condition of the insulation on wires is good, all mechanical connections are tight and all connections are free from corrosion. In boats operated in salt water it is especially important that all connections be inspected two or three times each year. If necessary, each connection should be taken apart, cleaned with fine sandpaper, given a light coating of vaseline to retard corrosion and tightly reconnected. Battery terminals should be cleaned often with water and baking soda, coated with vaseline and reconnected. High tension leads must be in good condition. Even a small crack in the insulation might permit oil or moisture to cause a partial ground requiring replacement of the lead.

### IGNITION TIMING

To set the ignition timing use a timing light. The flywheel is provided with a timing mark on its rim and an ignition timing indicator is positioned over the flywheel ring gear. With the timing light connected to the battery and No. 1 spark plug (port side at flywheel end) and the engine run at idle (500 RPM) set the distributor so that the timing light shows the flywheel timing mark directly in line with the ignition timing indicator.

Recheck ignition timing after tightening the distributor to be sure that it is properly set.

### IGNITION CIRCUIT

The distributor should be inspected every 100 operating hours or not less than every six months. Make sure the vent hole in the bottom of the distributor housing is kept open. After removing the distributor cap, inspect the breaker contacts. If the con-

tacts are grayish in color and are not more than slightly pitted they need not be replaced. We recommend that new breaker contacts be installed when required rather than attempting to reface the old contacts. Breaker contacts should be set with a gap of .020 inch. The ignition timing should always be reset using a timing light. Inspect all wires and connections and clean up any corrosion at connections if present.

Spark plugs should be cleaned and regapped periodically. Make certain there are no cracks in the porcelain and that the terminals are clean and tight. Any spark plug which is found to have burned or badly worn electrodes should be replaced. For Model "431" Chris-Craft Marine Engines we recommend Champion F-10 spark plugs and the correct gap is .030 inch.

### BATTERY

The battery should be kept near full charge. To check the condition of the battery, specific gravity readings should be taken. For further detail concerning batteries consult your Boat Owner's Manual.

Also keep the battery filled with pure water to the proper level (distilled water is best). Never let the level go below the top of the plates in the battery.

### ALTERNATOR AND VOLTAGE REGULATOR

The model "431" engine is equipped with a 40 ampere Alternator which performs the same function as the direct current generators used on other engines. The alternator produces alternating current which is changed to direct current by self contained rectifiers. Alternators have the advantage of charging at low engine R. P. M. which makes them ideal for boat operation.

The output of this alternator is as follows:

Engine R. P. M.	Amperes
500	7
1000	25
2400	40

The following cautions should be observed to prevent damage to the alternator.

1. Engine is wired with a negative ground system. Do not reverse polarity.
2. Do not attempt to polarize alternator. It is not necessary and could destroy alternator.
3. When using a dockside battery charger, disconnect battery terminals. Never use a "fast charger" to supply starting voltage.
4. Be careful not to accidentally ground the battery lead or stud on the alternator.

### MAINTENANCE

Make sure the alternator is mounted securely in place. Check the drive belt tension and alignment carefully, particularly after installation of new belts. Retightening new belts is very often necessary after a few hours operation or after storage.

NOTE: If the alternator fan can be rotated by pulling on a fan blade with one finger, the belt is too loose and must be tightened.

The alternator and voltage regulator should only be adjusted and repaired by authorized service stations which have instruments and information necessary to correctly repair these units.

### STARTING MOTOR

Make certain the starting motor is mounted securely and the Bendix drive is free from dirt. If the Bendix drive accumulates gummy deposits, these should be cleaned using a non-inflammable solvent and a brush. After cleaning, apply #10 engine oil sparingly to the armature shaft and screw threads.

The starting solenoid should be clean, connected securely and operating properly.

## FUEL SYSTEM

### CAUTION - FUEL REQUIREMENT

The gasoline recommended for Chris-Craft Marine Engines is a Marine leaded fuel but must have a minimum octane rating of at least 92 research method. When Marine white gasoline is used the same above octane rating is recommended and it is also recommended to occasionally use marine leaded fuel, particularly in new engines or after overhaul.

### CARBURETOR

The carburetor is guaranteed and serviced by the manufacturer and his distributors. Check the carburetor name plate for manufacturer.

It is important that all fuel connections be kept tight and that dirt be kept out of the carburetor. Periodically clean the carburetor flame arrestor and empty any deposit out of the fuel filter sediment bowl.

The carburetor is equipped with non-adjustable high speed jets which require no attention.

The idle adjusting needles should be turned to the position where the engine idles smoothest at 500 to 600 RPM.

### FUEL PUMP

The mechanical fuel pump furnished with the engine is guaranteed and serviced by the manufacturer.

## COOLING SYSTEM

### OPERATION

The sea water is taken in thru a strainer in the bottom of the boat and thru a positive displacement pump that is mounted on the starboard side of the engine.

This pump (referred to as a sea water pump) has dual inlets and outlets which allows an equal amount of water to flow thru the engine oil cooler (mounted on the starboard

side) and the reverse gear oil cooler (mounted on the port side). The sea water pump has a capacity of 15 G.P.M. per outlet or 30 G.P.M. total capacity at 5-1/2 P.S.I.

From the oil coolers the water is circulated thru two pressure relief valves, one on each oil cooler outlet. Each valve has a two pound relief spring. Until such a time that the engine is completely filled with water and has built up a two pound back pressure all water from the sea water pump is forced into the engine (or circulating pump inlet) that is with the exception of a small quantity that is allowed to pass thru small vent holes in the pressure relief valves. This water passes into the exhaust elbow adapters and then overboard thru the exhaust pipe. The reason for these vent holes is to eliminate any air from being trapped in this part of the system.

After the sea water pump has built up a pressure in the engine to two pounds then the pressure relief valves are forced open by pressures from the gear pump allowing the water to flow out thru the adapters and exhaust pipe overboard.

The function of the sea water pump is as follows:

1. To cool the engine oil and reverse gear oil to a satisfactory operating temperature.
2. To maintain a constant supply of water to the engine circulating system at all times.
3. To help cool and muffle the exhaust pipe.

The circulating system consists of a centrifugal pump mounted on the front of the engine. This pump circulates approximately 70 G.P.M. thru the engine at sixteen pounds pressure. The pump has one inlet and two outlets. Water from the two outlets is forced thru water lines to headers on the front end of each exhaust manifold. These manifolds have a water jacket completely around the exhaust area for cooling the hot exhaust gases. The water makes one pass thru the exhaust manifold and out thru an adapter on the rear end of the exhaust manifold. From the adapter the water flows thru the rear cover and into the rear end of the cylinder block. The water continues on thru the cylinder block, cylinder head and out thru the front end of the intake manifold.

Located at the front end of the intake manifold is a thermostat and thermostat housing. This is a 130° to 150° bypass type thermostat.

The function of this thermostat is to maintain a constant water temperature from the intake manifold water outlet. If the water in passing thru the engine has not reached a high enough temperature the thermostat will allow the water to pass straight thru and into the circulating pump inlet, except for a small amount which can go through a bleed hole in the thermostat to eliminate air locks. If, however, the water temperature has reached a maximum high and this is controlled by the thermostat range, the thermostat will close off a portion of the water to the circulating pump and at the same time will allow water to pass out thru another chamber in the thermostat housing. This water then goes thru a tee which diverts part of the flow to the starboard adapter then out thru the exhaust pipe and part of the flow to the port adapter then out thru the exhaust pipe.

When water is allowed to pass overboard it takes water away from the circulating system. This water, however, is replaced by the sea water pump which, in the meantime, has been holding two pound pressure against the circulating pump inlet as described in the sea water system.

When engine is idling at 500 R.P.M. the circulating pump is pumping a minimum flow of water thru the exhaust manifolds. With the engine installed at an angle it could

### COOLING WATER FLOW CHART IN A CHRIS CRAFT V-8 MODEL "431" MARINE ENGINE

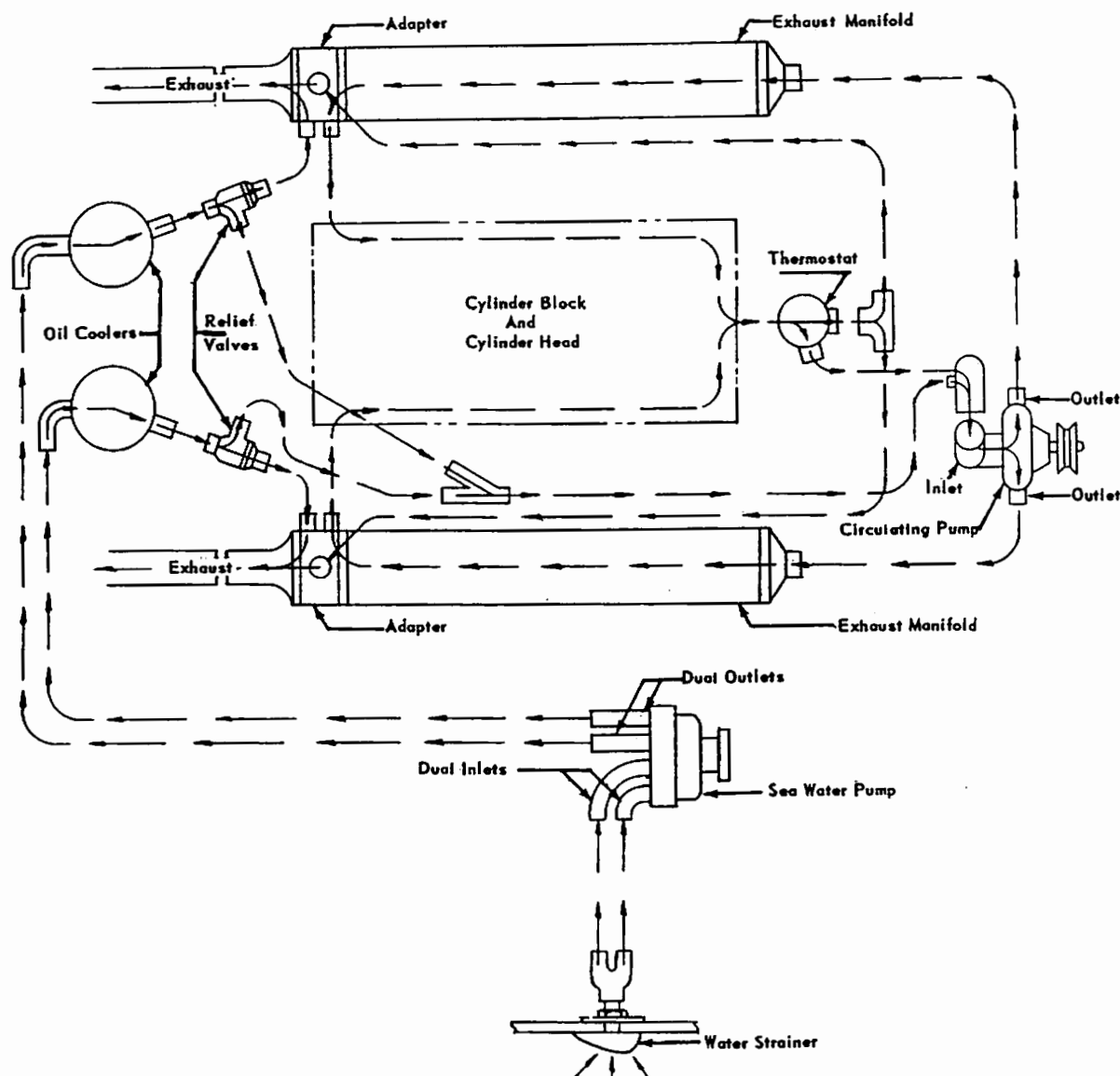

mean that the water jacket on the high end of the exhaust manifold would not be completely filled. This could cause a steam or air pocket to exist, therefore, we have added a bleed line from each exhaust manifold header into the intake manifold water jacket.

The main purpose of the circulating system is the dissipation of heat generated by combustion and maintaining proper uniform temperatures throughout the engine. This is accomplished by providing a recirculating pump of sufficient volume to increase the velocity of engine jacket water.

#### WATER TEMPERATURE

The water temperature gauge is not absolutely necessary, but if one is installed the reading shown will be a good indication that there are no obstructions in the water passages, and that the water pumps, thermostat, and pressure valves are operating properly. Normal water temperature reading will be approximately 140°.

#### MAINTENANCE

Normal maintenance for these pumps includes attention to drive belts and hoses, keeping them properly tight and replacing them if inspection shows them to be deteriorated.

## **VALVES AND VALVE TAPPETS**

Good valve action is very important to the efficiency and smoothness of the engine.

The need for valve grinding will first be indicated by loss of engine speed, increased fuel consumption and rough idling. A check of the compression in each cylinder is a reliable check of valve condition.

Engines operated with proper care will require a minimum amount of valve Maintenance.

In the new engine, check valve clearance after ten to twenty hours of operation. Valves should be checked every 100 hours of operation and anytime the head is removed or the head bolts are adjusted. Clearance adjustments should be made while the engine is hot. Intake valve clearance should be .025", and exhaust valve clearance should be .025".

## **REVERSE GEAR**

### **PARAGON HYDRAULIC REVERSE GEAR**

The hydraulic section of the reverse gear is completely contained within the reverse gear housing. No adjustment is needed for the forward and the reverse drive.

The hydraulic reverse gear uses an oiling system separate from the engine lubricating oil. Keep the reverse gear oil level up to the full mark indicated on the oil test rod in the reverse gear unit. When it is necessary to add oil to the reverse gear, use only automatic transmission fluid Type "A". Change the reverse gear oil every fifty to one hundred hours depending upon the type of service to which the engine is subjected.

# REVERSE GEAR

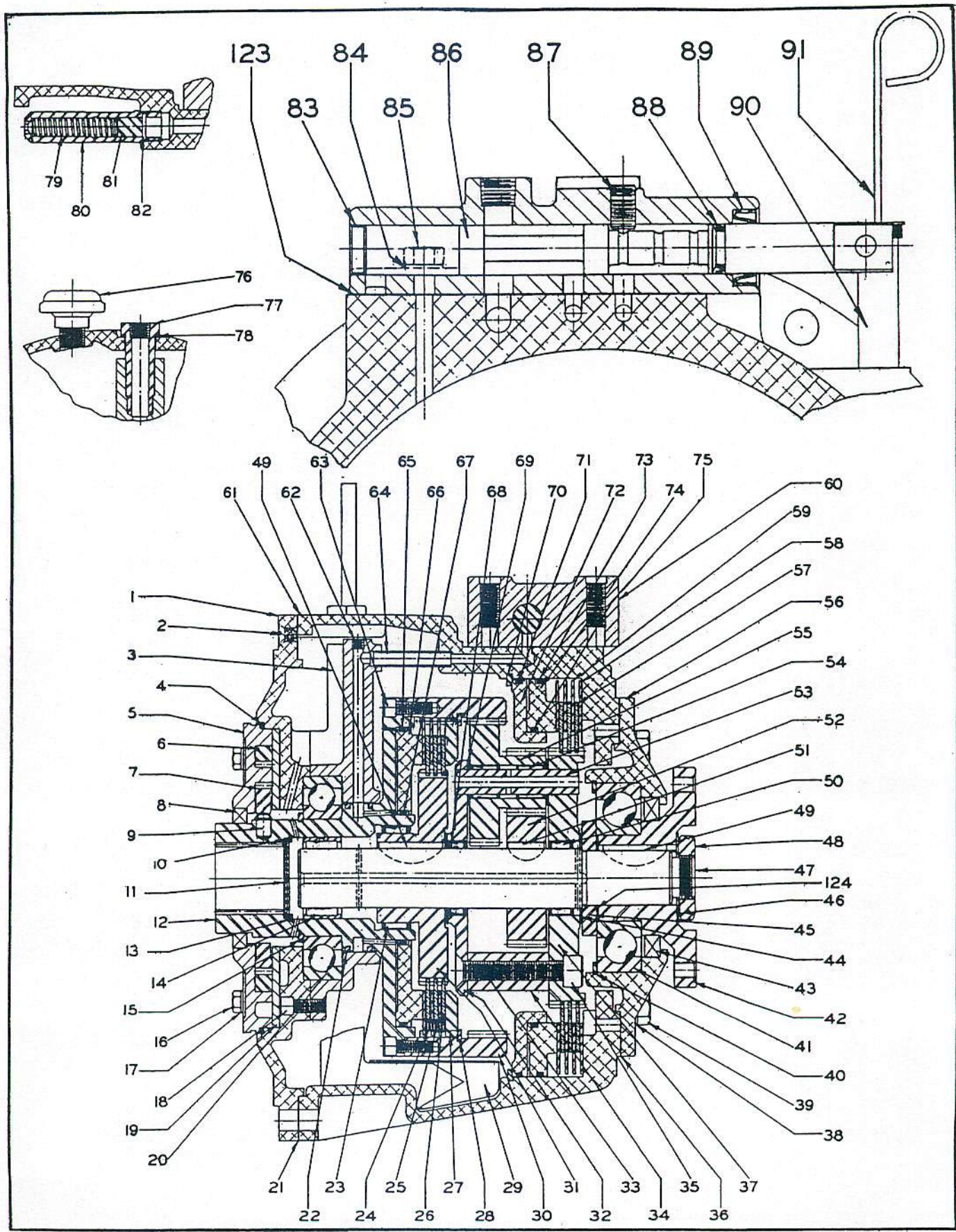

## ANNUAL LAY-UP

In areas where freezing is a problem, preparing the engine becomes a major consideration because of the potential damage from freezing. This does not infer that lay-ups in more temperate climates are less important and therefore less exacting. A thorough lay-up operation will include the following steps:

1. Drain the engine oil and refill the crankcase. Add Chris-Craft Crankcase Oil Supplement, part number 20630, in the proportion of 16 ozs. for every four to six quarts of oil.
2. Before lifting the boat from the water, add Chris-Craft Fuel Conditioner and Valve Lubricant, part number 20629, to the gasoline supply in the proportion of 6 oz. to each 7 gallons of gasoline. We suggest running the fuel supply low at the end of the season, thereby reducing the required amount of Fuel Conditioner. If preferred, the treated fuel may be fed from an auxiliary tank. An outboard motor gasoline tank would serve very well for this purpose. Run the engine for at least fifteen minutes to disperse the Conditioner throughout the engine. The conditioning properties lie in the residue resulting from the combustion of the Fuel Conditioner, therefore it is very important to run the engine as directed. During this final running, close the fuel valves at the tanks and run the engines until they stall.
3. Remove and clean the sediment bowls, and replace them.
4. Drain the entire cooling system, and flush with fresh water. This is especially important for boats operated in salt water. Drain plugs (painted red) and other critical drainage spots are located as follows:
  - (a) Remove 2 Capscrews - lower rear capscrew attaching each Exhaust Manifold to block.
  - (b) Remove 4 Pipe Plugs - 1 in front and rear of each Exhaust Manifold.
  - (c) Remove the Pipe Plug in tee under Port Exhaust Manifold Adapter.
  - (d) Remove the 2 Capscrews in Cylinder Block (1 on each side).
  - (e) Remove the Plug in Bottom of Water Pump.
  - (f) Remove Thermostat Drain Plug.
  - (g) Remove Plug in Brass Tee on top of Thermostat.
  - (h) Loosen Housing on Pressure Relief Valves to drain.
  - (i) Disconnect two Outlet Hoses at Sea Water Pump.
5. Pull the boat out of the water, bow first, to insure complete drainage of the exhaust pipe and the muffler. If the boat is lifted vertically, the same result can be accomplished by keeping the bow higher than the stern.
6. Remove the battery or batteries, and arrange to have them charged periodically throughout the inactive period. An uncharged battery will become damaged. Wash the exterior of each battery with a baking soda solution to remove all traces of corrosion and acid.

7. Plug or tape the exhaust pipes to prevent moisture from entering valve chambers during storage.
8. Seal the flame arrestor against dirt and moisture. This can be done by placing masking tape on the top faces, or by using an airtight plastic bag in which to enclose the entire carburetor.
9. Cover the fuel-tank-through-hull vent and the gas-cap vent, making them air-tight.
10. Repaint blemished areas with Chris-Craft blue engine enamel which is available in handy "Spray-On" cans.
11. Apply a film of Chris-Craft Oil Supplement on all exposed, unpainted metal surfaces.
12. Remove the distributor cap and oil the advance mechanism. Apply a light coating of Chris-Craft Oil Supplement to the distributor points and the cam. Replace the distributor cap. Apply grease to the zerk fitting at the tachometer drive on the distributor.

## **ANNUAL FITTING OUT**

1. Replace all drain plugs and re-connect all hoses loosened during the lay-up cycle.
2. Replace and re-connect the battery or batteries, making certain they are adequately charged and filled with water.
3. Remove plugs from the exhaust pipes.
4. Remove covering from carburetor or flame arrestor.
5. Uncover fuel tank vent and gas cap vent.
6. Remove excess oil from internal distributor parts.
7. Start the engine. See Page 3 for starting instructions.

## **MAINTENANCE SCHEDULE**

The following maintenance schedule is offered as a suggestion only. Maintenance requirements will vary according to the engine usage.

Each time the engine is run:

Measure oil level in engine and in the reverse gear.

Check fuel level.

Make sure cooling water is circulating after starting engine.

Battery water should be brought up to level every one or two weeks.

Every 50 hours running:

Change oil (every 50 to 100 hours depending on type of service).

Clean carburetor flame arrestor.

Clean any dirt out of fuel filter bowl.

Clean ventilating valve located near carburetor each time oil is changed.

Distributor - Apply grease to zerck fitting at tachometer drive.

Correct any general fuel or water leaks.

Every 100 hours running (or not less than every 6 months).

Change Hydraulic Reverse Gear Oil.

Clean and tightly re-connect all dirty electrical connections.

Replace deteriorated rubber hoses.

Replace oil filter element every 100 running hours.

Remove distributor cap and distributor rotor. Place fingers over the two holes in the shaft just above the cam to allow the oil to pass beyond these holes and apply about three drops medium engine oil through the top of the shaft. Put 1 drop of light engine oil on breaker arm pivot pin. Wipe off excess. Put light film of grease on breaker cam. Wipe off excess. Examine condition of ignition breaker contacts and set gap to proper dimensions.

Examine spark plugs. Clean or replace plugs which are dirty or show evidence of burning.

Set ignition timing, using a timing light.

Align engine using feeler gauge at engine coupling.

Re-adjust valve clearance to compensate for normal wear.

Examine condition of engine paint. "Aerosol Spray Paint" of blue engine enamel is available for touchup.

## **ENGINE INSTALLATION RECOMMENDATIONS**

### **MOUNTING**

A rigid bed should be prepared for mounting the engine. Heavy wood engine stringers running fore and aft in the boat with proper cutouts for mounting the engine supports are usually used.

## ALIGNMENT

Proper alignment with the propeller shaft is important for engine efficiency and smoothness. The two coupling faces (one on engine and one on shaft) must be parallel. Use a feeler gauge or piece of shim stock not more than .003 inch in thickness. When coupling faces are brought together by hand, not bolted, the .003 feeler should be tightly gripped at all points around the edges of the coupling. Alignment must be correct when couplings are viewed from the side as well as when seen from the top. It is necessary to lift lightly on the shaft and coupling to compensate for the weight of those two items but be very careful that only the weight is lifted and the shaft is not sprung. To adjust any misalignment the corners of the engine may be raised or lowered by using tapered cast iron wedges.

## EXHAUST

The cooling water overflow is routed into the exhaust tube directly out of the exhaust manifold. The flow of water through the exhaust tube will cool the exhaust and in addition will help to quiet the exhaust noise.

We recommend that copper tubing, exhaust hose or iron pipe of proper diameter be used for the exhaust pipe. Copper tubing can be bent as needed to fit a particular installation or can be welded giving the required angles. Be sure to use correct diameter exhaust pipe and keep bends to a minimum to insure least amount of exhaust restriction possible.

## RECOMMENDED EXHAUST SIZES

Model "431" - dual exhaust	3-1/4" I. D. each.
Model "431" - single exhaust	4-1/2" I. D. each.

We strongly recommend the use of standard Chris-Craft exhaust elbows for connecting from the exhaust manifold to copper tube or exhaust hose water cooled exhaust systems. The exhaust elbows are designed to give minimum back pressure and are easy to install.

## COOLING WATER INTAKE

The dual water pump requires two inlet hoses. 1" I. D. hose which will not collapse easily should be used. Dual 1" intake thru-hull fittings may be used or a neat installation can be made using a single Chris-Craft 1-1/4" pipe thread intake scoop and a Chris-Craft #6995 "Y" fitting (dual hose adapter).

## ENGINE CONTROLS

Various controls will have to be connected to the engine. All linkages should be made strong enough to withstand any strain to which they will be subjected and direct positive action is necessary in all connections. Keep play at a minimum.

Suitable throttle controls should be installed and connected to the proper carburetor arms. Make sure that the throttle on the carburetor will open and close all the way.

All switches should be resistant to rust and corrosion for marine use. They should be connected as shown in the wiring diagram.

### INSTRUMENTS

An oil pressure gauge, tachometer and ammeter should be installed. For the oil pressure connection a plug can be removed from the connection in the starboard oil cooler. The tachometer drive cable should be connected immediately below the ignition distributor. The cable is driven at one half engine speed and a suitable tachometer should be used. The ammeter should be wired into the electrical circuit as detailed on the engine wiring diagram. If desired a temperature gauge may also be installed. There is a threaded hole suitable for the insertion of a temperature gauge sender at the front of the engine in the intake manifold.

### INFORMATION AVAILABLE

We are in a position to offer engineering assistance to all who are operating Chris-Craft boats or who are making Chris-Craft engine installations. If you wish general data or information concerning an individual problem send us full details. We will be happy to give a propeller size suggestion to improve present performance, or for a new installation.

### ROTATION DIAGRAM

#### Standard Chris-Craft Engine Installation

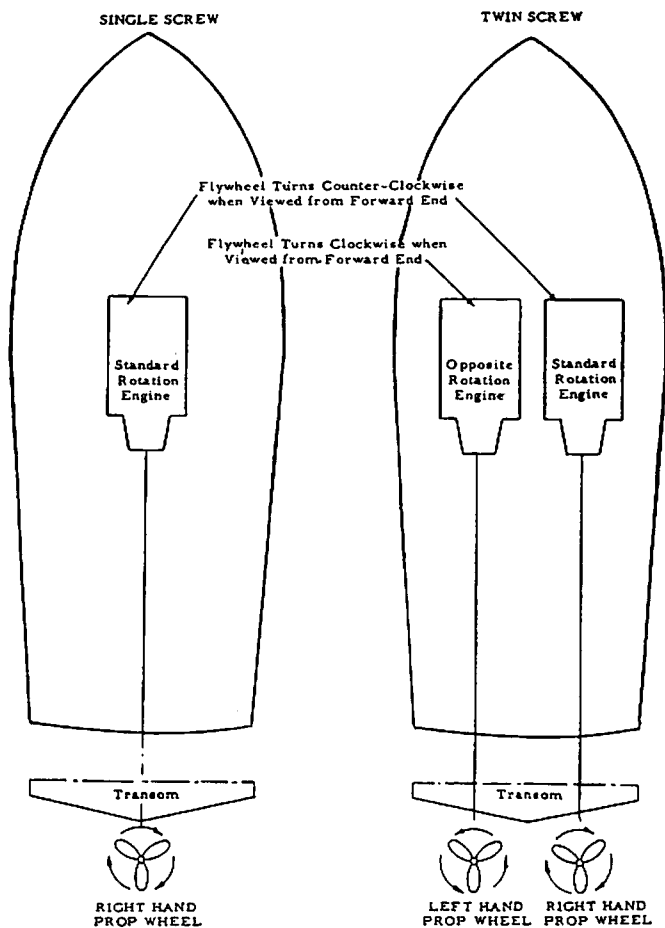

# WIRING DIAGRAM MODEL "431" V-8 ENGINE

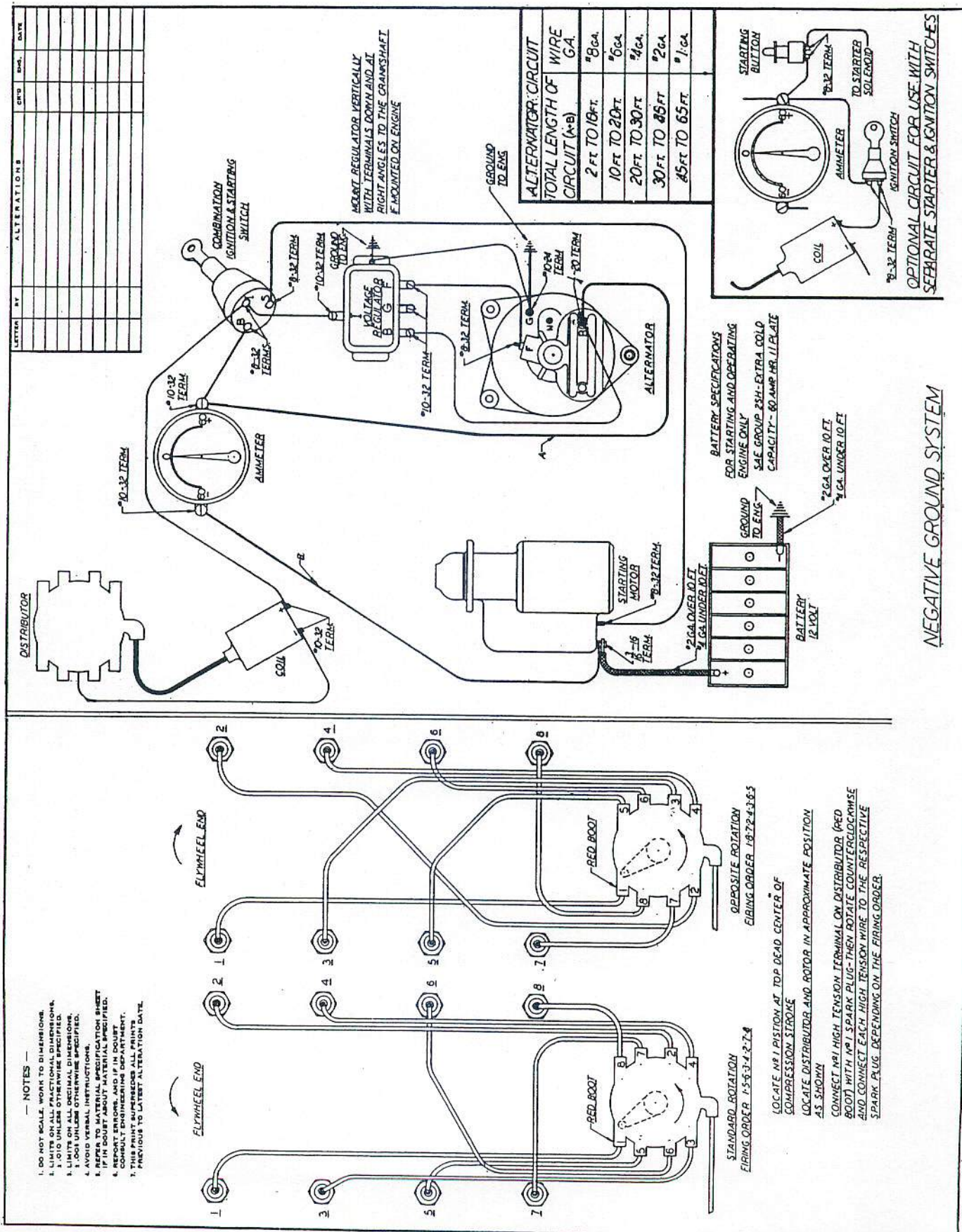

TOTAL LENGTH OF WIRE CIRCUIT (A+B)	WIRE G.A.
2 FT. TO 10 FT.	#8 GA.
10 FT. TO 20 FT.	#6 GA.
20 FT. TO 30 FT.	#4 GA.
30 FT. TO 45 FT.	#2 GA.
45 FT. TO 65 FT.	#1 GA.

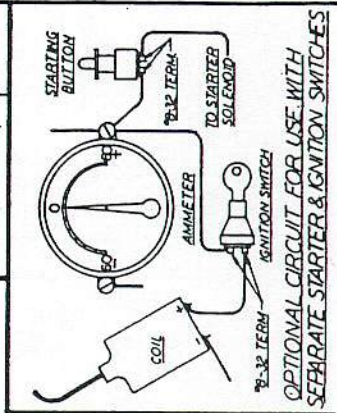

BATTERY SPECIFICATIONS FOR STARTING AND OPERATING ENGINE ONLY  
 SAE GROUP 25H-EXTRA COLD CAPACITY- 60 AMP HR. 11 PLATE  
 2 GA. OVER 10 FT.  
 9 GA. UNDER 10 FT.

NEGATIVE GROUND SYSTEM

- NOTES —
- DO NOT SCALE. WORK TO DIMENSIONS.
  - LIMITS ON ALL FRACTIONAL DIMENSIONS.
  - .010 UNLESS OTHERWISE SPECIFIED.
  - LIMITS ON ALL DECIMAL DIMENSIONS.
  - ALL DIMENSIONS UNLESS OTHERWISE SPECIFIED.
  - AVOID VERTICAL INSTRUMENTATIONS.
  - REFER TO MATERIAL SPECIFICATION SHEET IF IN DOUBT ABOUT MATERIAL SPECIFIED.
  - REPORT ERRORS, AND IF IN DOUBT, CONTACT THE DESIGN ENGINEER.
  - THIS PRINT NUMBERS ALL PRINTS.
  - PREVIOUS TO LATEST ALTERATION DATE.

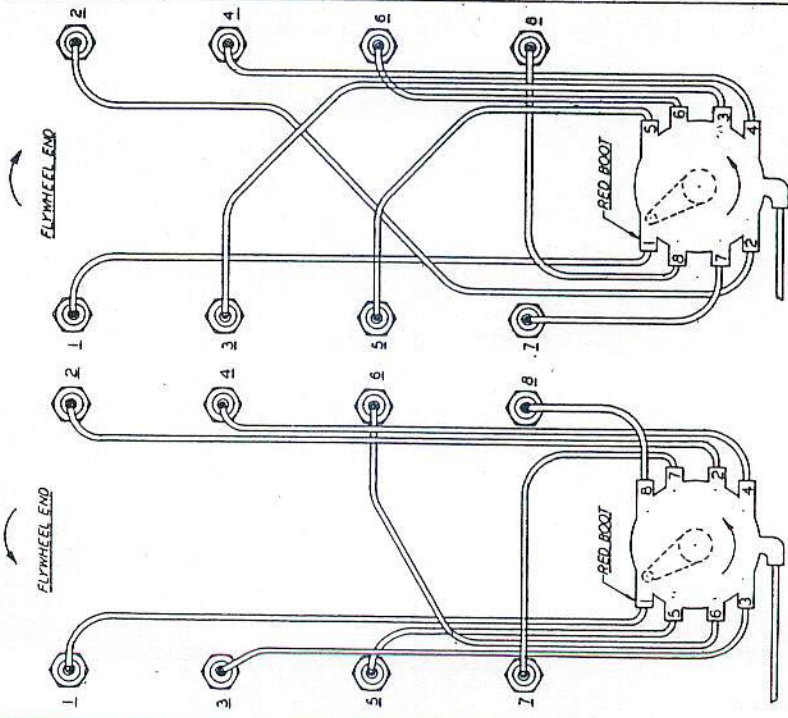

# TYPICAL *Chris-Craft* ENGINE SHOWING MAJOR PARTS

