

Marine Power

for Models:

307-Q
200H.P.

327-Q
230H.P.

350-Q
235H.P.

P
A
R
T
S
L
I
S
T

THERMOCON MARINE ENGINES



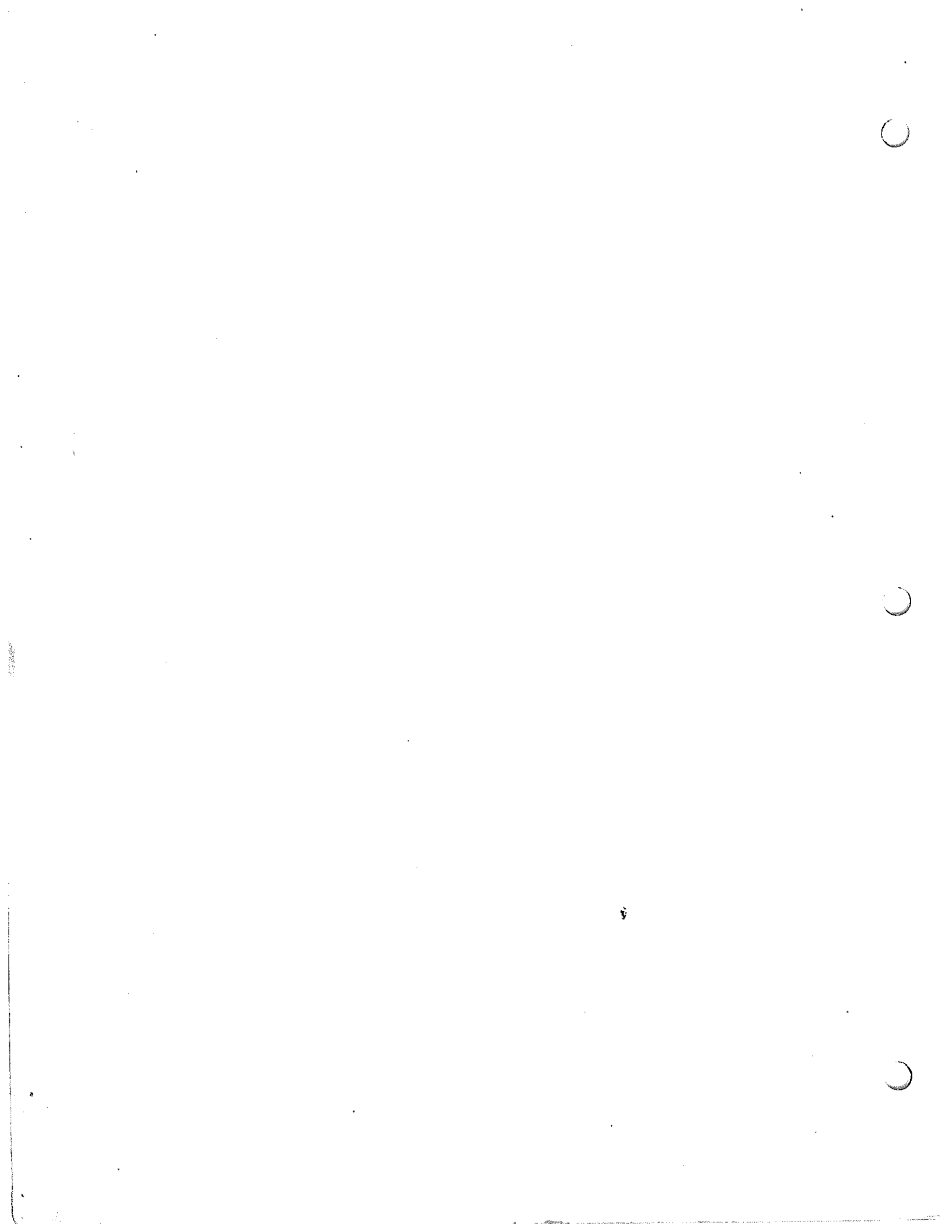

TO ORDER PARTS

ENGINE MODEL and ENGINE SERIAL NUMBER must be furnished when replacement parts are required.

The model designation (*) and serial number (*) will be found stamped into a plate fastened on top of the exhaust manifold.

ILLUSTRATION OF ENGINE PLATE

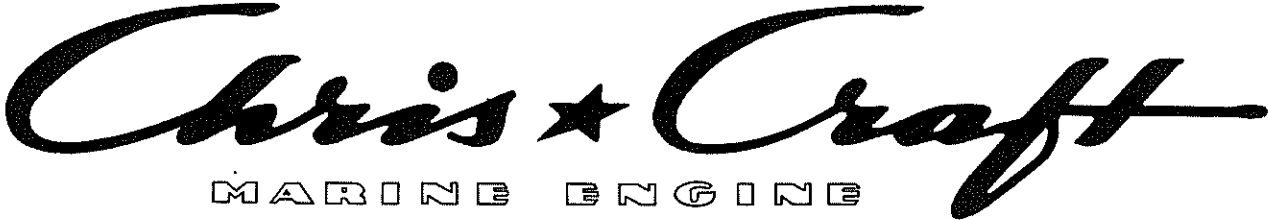
 MARINE ENGINE			
WHEN ORDERING PARTS SPECIFY MODEL AND ENGINE NUMBER	MODEL *****	FIRING ORDER	ENGINE NO. *****
CHRIS-CRAFT CORPORATION		POMPANO BEACH, FLORIDA U.S.A.	
			USE ONLY HIGH GRADE HEAVY DUTY MARINE ENGINE OIL SAE 30 OR 10W-30

Order parts from your nearest Chris-Craft dealer or direct from Chris-Craft Corporation, Service Parts Department, Algonac, Michigan being sure to furnish numbers mentioned above.

**For the best performance from your engine —
INSIST ON GENUINE CHRIS-CRAFT PARTS.**

Instructions, specifications and illustrations shown are in accordance with experience and product information as developed at time of publication. The right is reserved to make changes at any time without notice.

SERVICE YOUR CHRIS-CRAFT WITH CHRIS-CRAFT SERVICE



ALPHABETICAL INDEX

<u>SUBJECT</u>	<u>PAGE NO.</u>	<u>SUBJECT</u>	<u>PAGE NO.</u>
ALTERNATOR	29	MANIFOLD, EXHAUST	21
BELT, ALTERNATOR	29	Manifold, Intake	16
Bearings	7	Mounts	4, 5
Block, Cylinder	3	OIL COOLER	39
CAMSHAFT	6	PAN, OIL	11
Cap	22	Pistons	10
Carburetor	17	Plugs	23
Coil	13	Points	22
Condensor	22	Pump, Circulating	35
Crankshaft	7	Pump, Fuel	19
Couplings	38	Pump, Oil	11
DAMPER DRIVE	7	Pump, Seawater	31, 33
Dipstick	11	RISERS	21
Distributor	22	Rods, Connecting	10
ELBOWS, EXHAUST	21	STARTER	25
Engine Assembly	3	Shunt	25
Engine Specifications	1	TACHOMETER DRIVE	9
FILTER, FUEL	19	Thermostat	17
Filter, Oil	13	Timing Chain Cover	9
Firing Order	2	V-DRIVES	50, 51
Flywheel	7	Valves	14, 15
Flywheel Cover	8	Vent Valve	19
Fresh Water Cooling	36, 37	Voltage Regulator	29
GASKET SETS	4, 38	WIRING	27
Gear, Reverse	38	PAINT	
Ground, Electrical	4	White 11.88-88100	
HEAD, CYLINDER	15	Blue 11.15-99800	

Chris-Craft

ENGINE SPECIFICATIONS

		307Q Series	327Q Series	350Q Series
ENGINE	Type	4 Cycle - V-8		
	Displacement	307	327	350
	Horsepower	200	230	235
COMPRESSION		150 psi		
SPARK PLUG		AC MR 43 T	Champion UJ-6	AC MR 43 T
GAP		.028"		
DISTRIBUTOR	Point Dwell	28		
	Point Gap	.020"		
	Arm Spring Tension	19-23 ounces		
	Condenser	.18-.23 microfarad		
	Timing Adv. (Degrees)	4°	4°	4°
MAXIMUM TORQUE		297 @ 3000 RPM	328 @ 3200 RPM	323 @ 3200 RPM
BORE		3 $\frac{7}{8}$ "	4"	
STROKE		3 $\frac{1}{4}$ "		3.48"
NOMINAL COMPRESSION RATIO		8.0:1	8.8:1	8.5:1
IDLE SPEED		500 RPM		
OIL PRESSURE		10 lbs. @ Idle		
OIL CAPACITY		6 to 7 qts.		
FIRING ORDER	RH	1-5-6-3-4-2-7-8		
FIRING ORDER	LH	1-8-7-2-4-3-6-5		

Chris-Craft

FIRING ORDER

307QL-327QL-350QL

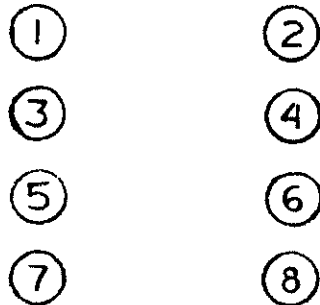
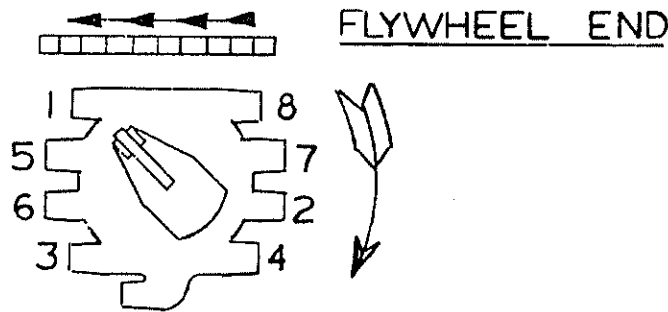

L.H. ROTATION

307Q-327Q-350Q

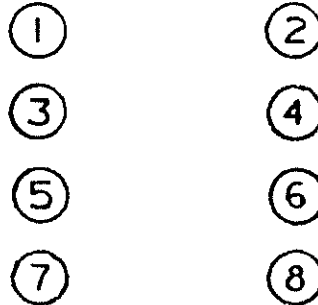
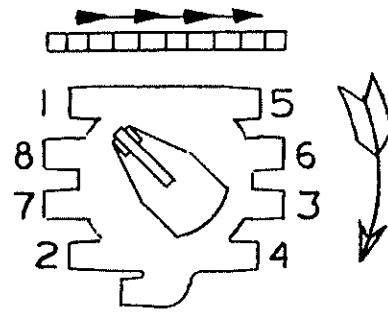

R.H. ROTATION

MODEL	ROTATION FROM SHAFT COUPLING END	FIRING ORDER
307Q-327Q-350Q	CLOCKWISE	1-5-6-3-4-2-7-8
307QL-327QL-350QL	COUNTER-CLOCKWISE	1-8-7-2-4-3-6-5

Valve adjustment is made by backing off the adjusting nut (rocker arm stud nut) until there is play in the valve push rod and then tightened to just remove all push rod to rocker arm clearance. This may be determined by rotating push rod with fingers as the nut is tightened. When rod does not readily move in relation to the rocker arm, the clearance has been eliminated. The adjusting nut should then be tightened an additional 1 turn to place the hydraulic lifter plunger in the center of its travel. No further adjustment is required.

With the engine in the number 8 firing position as determined above, the following valves may be adjusted.

307Q-327Q-350Q exhaust 8-6-5-1 intake 8-7-4-2
 307QL-327QL-350QL exhaust 2-4-7-8 intake 1-5-6-8

Crank the engine one revolution. This is number 3 firing position. With the engine in this position, the following valves may be adjusted.

307Q-327Q-350Q exhaust 7-4-3-2 intake 6-5-3-1
 307QL-327QL-350QL exhaust 1-3-5-6 intake 2-3-4-7

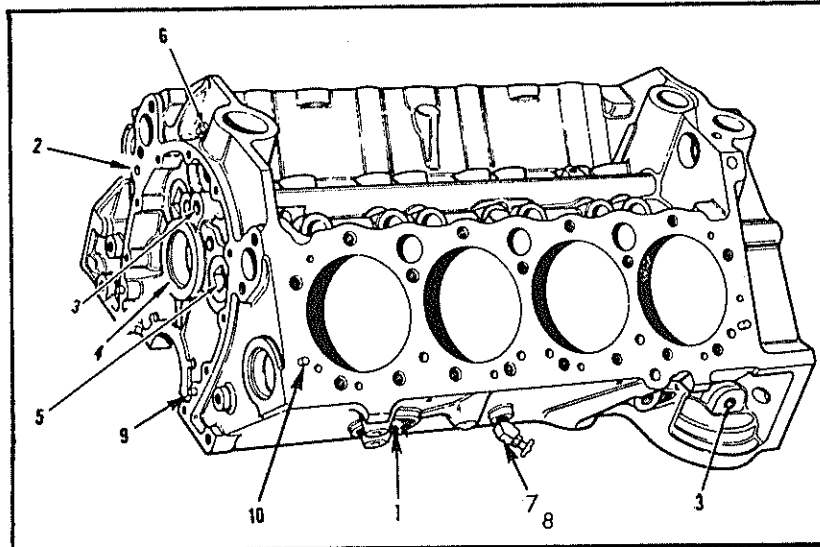

Code No.	Part No.	No. Req'd	Name
			<u>STRIPPED ENGINE</u>
	16.11-10064	1	Block W/Fitted Pistons 307Q-307QA R.H. Rot.
	16.11-10063	1	Block W/Fitted Pistons 307QL-307QL L.H. Rot.
		1	Block W/Fitted Pistons 327Q-327QA R.H. Rot.
		1	Block W/Fitted Pistons 327AL-327QAL R.H. Rot.
	16.11-10066	1	Block W/Fitted Pistons 350Q-350QA R.H. Rot.
	16.11-10065	1	Block W/Fitted Pistons 350QL-350QAL L.H. Rot.
			NOTE: Stripped Engine Assembly—Discontinued. Sell cylinder block only W/Fitted Piston.

CYLINDER BLOCK

	16.11-20007	1	Cylinder Block Assembly—307Q-307QA Series
	16.11-00439	1	Cylinder Block Assembly—327Q-327QA Series
	16.11-20050	1	Cylinder Block Assembly—350Q-350QA Series
			NOTE: Cylinder Block Assembly includes fitted pistons, ring assemblies and bearings.
1	16.74-10000	8	Cup plugs 1 $\frac{5}{8}$ " Brass
2	16.74-10001	1	Cup plugs $\frac{3}{8}$ " Brass (rear of block below LH water inlet)
3	16.11-00090	6	Cup plugs $\frac{1}{2}$ " (oil galleries)
4	16.11-00089	1	Cup plugs 2 $\frac{1}{8}$ " (camshaft front bearing hole)
5	16.11-00088	2	Plug 1 $\frac{1}{4}$ " Sq. Socket (water jacket) 327 Series
6	16.58-10153	1	Pipe Plug $\frac{1}{8}$ " Slotted Head (oil pressure hole)
	16.11-00318	3	Pipe Plug $\frac{1}{4}$ " Sq. Head (oil galleries)
7	16.58-17982	2	Valve Drain $\frac{1}{4}$ " Brass (water drain—each side)
8	16.58-10016	2	Elbow, St. 45 $\frac{1}{4}$ " MPT
9	16.47-00007	2	Dowel Pin $\frac{1}{4}$ " x $\frac{7}{8}$ " (align timing chain cover to block)
	16.11-00086	2	Dowel Pin $\frac{1}{4}$ " x $\frac{5}{8}$ " (at oil pump flange)
	16.11-00093	2	Dowel Pin $\frac{5}{8}$ " diameter (align front cover)
10	16.11-00092	4	Dowel Pin $\frac{1}{16}$ " x $\frac{1}{16}$ " (at cylinder deck)
	16.11-00086	1	Dowel Pin $\frac{1}{4}$ " x $\frac{5}{8}$ " (cylinder block to front bearing cap)

Chris-Craft

Code No.	Part No.	No. Req'd	Name
	<u>ELECTRICAL GROUND</u>		
	16.44-48419	1	Grounding Stud (leftside engines thru fuel pump mounting flange)
	16.41-10005	1	Washer $2\frac{3}{4}$ " x $1\frac{1}{16}$ " $\frac{1}{16}$
	16.36-10009	2	Nut $\frac{3}{8}$ "—24 Brass

GASKET SET

	16.50-90095	1	Complete Gasket Overhaul Set 307Q— 327Q— 350Q (Reduction Gear Gaskets must be ordered separately when required)
	16.50-90096	1	Complete Valve Grind Gasket Set

FRONT ENGINE MOUNTS

1	16.20-05432	2	Engine Mount Bracket
2	16.30-00202	4	Capscrew $\frac{7}{16}$ "—14 x $1\frac{1}{4}$ "
3	16.42-00007	4	Lockwasher $\frac{7}{16}$ "
4	16.93-05808	2	Engine Mount—Rubber
5	16.21-06260	2	Engine Mount Housing
6	16.41-05840	2	Engine Mount Retaining Washer
7	16.39-00006	2	Locknut $\frac{5}{8}$ "—11
8	16.30-00533	2	Capscrew $\frac{5}{16}$ "—18 x 2"
9	16.42-00003	2	Lockwasher $\frac{5}{16}$ "
10	16.42-00005	2	Plain Washer $\frac{5}{16}$ "

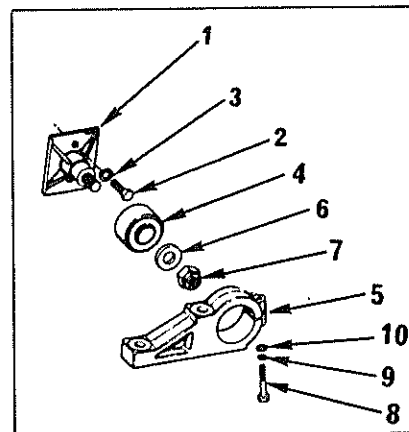
**REAR ENGINE MOUNTS (WITHOUT V-DRIVE)**

11	16.20-08363	2	Engine Mount Support
12	16.30-00202	2	Capscrew $\frac{7}{16}$ "—14 x $1\frac{1}{4}$ "
13	16.30-00222	2	Capscrew $\frac{7}{16}$ "—14 x $2\frac{1}{2}$ "
14	16.42-00007	4	Lockwasher $\frac{7}{16}$ "
15	16.72-07801	2	Engine Mount Stud
16	16.93-05808	2	Engine Mount
17	16.21-06260	2	Engine Mount Housing
18	16.41-05840	2	Engine Mount Retaining Washer
19	16.39-00006	2	Locknut $\frac{5}{8}$ "—11
20	16.30-00533	2	Capscrew $\frac{5}{16}$ "—18 x 2"
21	16.42-00003	2	Lockwasher $\frac{5}{16}$ "
21	16.41-00005	2	Plain Washer $2\frac{3}{4}$ "

NOTE: The following items are attached to the rear engine supports

22	16.70-06358	2	Lifting Ring
23	16.30-00127	2	Capscrew $\frac{3}{8}$ "—24 x $1\frac{1}{8}$ "
24	16.42-00004	2	Lockwasher $\frac{3}{8}$ "
25	16.36-00005	2	Hex Nut $\frac{3}{8}$ "—24

Code No.	Part No.	No. Req'd	Name
----------	----------	-----------	------

REAR ENGINE MOUNTS (WITH V-DRIVE)**NOTE:** Used on engines (with V-Drive) after engine 327-214833W

	16.20-00093	2	Bracket, Engine Support
	16.30-00202	4	Screw, Cap Hex Head $\frac{7}{16}$ "—4 x 1 $\frac{1}{4}$ "
	16.30-00124	2	Screw, Cap Hex Head $\frac{3}{8}$ "—16 x 1"
	16.20-08610	2	Bracket Engine Mount Support
34	16.44-08267	2	Engine Mount Adjusting Stud
35	16.72-08268	2	Engine Mount Retaining Shaft
36	16.21-08264	2	Engine Mount V-Drive Housing
37	16.93-05808	4	Rubber Engine Mount
38	16.57-07660	2	Engine Mount Spacer Washer
39	16.41-05840	2	Engine Mount Retaining Washer
40	16.39-00006	2	Engine Mount Retaining Nut $\frac{5}{8}$ "—11
41	16.30-00546	2	Capscrew $\frac{3}{8}$ "—16 x 1 $\frac{3}{4}$ " (Engine Mount Housing)
42	16.42-00012	2	Lockwasher $\frac{3}{8}$ "
43	16.36-07694	6	Hex Nut—Adjusting Stud
44	16.42-00012	4	Lockwasher
45	16.70-06358	2	Lifting Ring (attach one to each Eng. Mount Support Brkt.)
	16.72-00000	2	Bolt, Engine Mount
	16.72-08731	2	Spacer, Bolt

REAR ENGINE MOUNTS (WITH V-DRIVE)**NOTE:** Mounts used (w/V drives) before engine #327. 214834W

26	16.73-08245	4	Engine Mount Support Spacer
27	16.73-08266	2	Reverse Gear & V-Drive Support
28	16.30-00214	8	Capscrew $\frac{7}{16}$ "—14 x 2"
29	16.42-00007	8	Lockwasher $\frac{7}{16}$ "
30	16.20-08610	2	Engine Mount Support Bracket
31	16.30-00135	8	Capscrew $\frac{3}{8}$ "—24 x 1 $\frac{5}{8}$ "
32	16.36-00005	8	Hex Nut $\frac{3}{8}$ "—24
33	16.42-00004	8	Lockwasher $\frac{3}{8}$ "

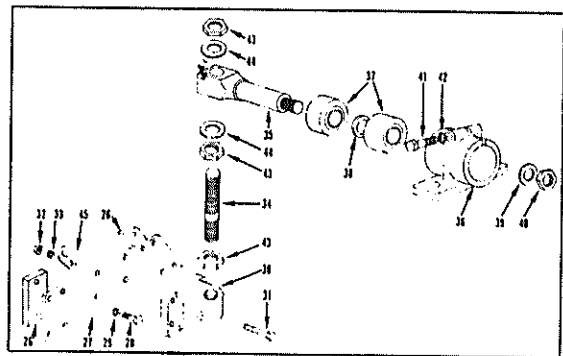
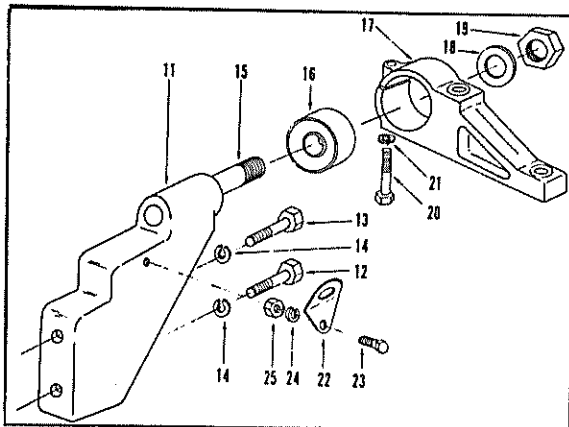

Chris-Craft

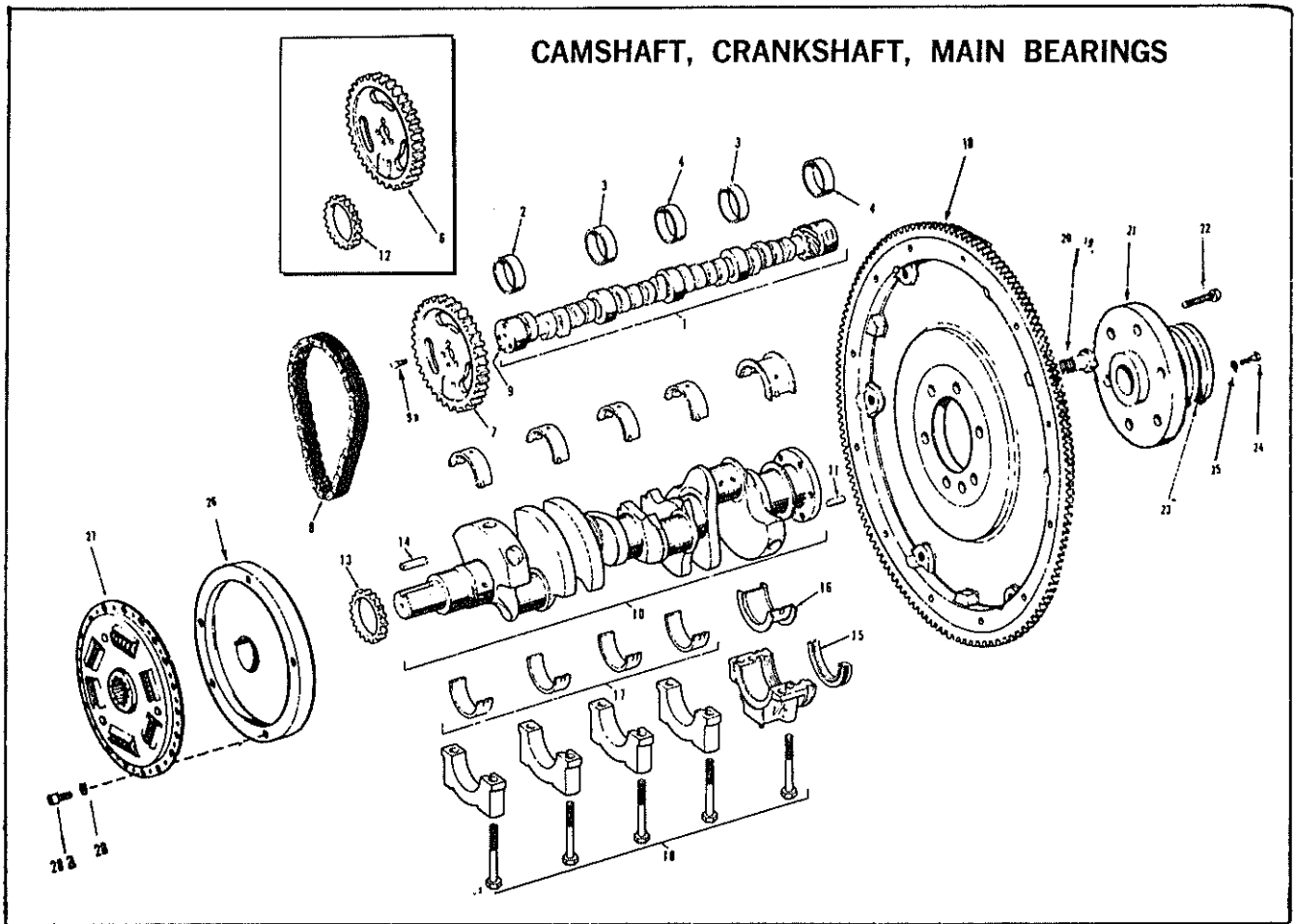

Code No.	Part No.	No. Req'd	Name
----------	----------	-----------	------

CAMSHAFT

1	16.11-00338	1	Camshaft Assembly—307Q, 327Q, 350Q RH Rot.
	16.11-00339	1	Camshaft Assembly—307QL, 327QL, 350QL LH Rot.
2			Camshaft Rear Bearing
3	16.96-08642	1	Camshaft Front & Rear Inter-Bearing } complete Bearing Set
4			Camshaft Front Inter & Center Bearing }
6	16.11-00046	1	Camshaft Sprocket—307Q, 327Q, 350Q, RH Rot.
7	16.11-00030	1	Camshaft Gear—307Q, 327Q, 350Q, LH Rot.
8	16.11-00045	1	Camshaft Timing Chain—307Q, 327Q, 350Q RH Rot.
9	16.11-00086	1	Camshaft Dowel Pin (incl. in Camshaft Assembly)
9(a)	16.11-00144	3	Camshaft Gear or Sprocket Bolt $\frac{5}{16}$ "—18 x $\frac{3}{4}$ "

NOTE: See end of front cover section for Camshaft thrust screw.

NOTE: It is very important that special camshaft lubricant be applied liberally to prevent damaging camshaft lobes when new camshaft or valves are installed. This lubricant can be ordered from Chris-Craft using part number 56.00-20630.

Chris-Craft

Code No.	Part No.	No. Req'd	Name
<u>CRANKSHAFT</u>			
10	16.11-00348	1	Crankshaft Assembly—307Q, 307QA Series NOTE: 16.11-00348 is used for engine before 307-103158 16.11-00371 is used for engine after 307-103157
	16.11-00283	1	Crankshaft Assembly—327Q, 327QA Series NOTE: 16.11-00283 is used for engines before 327Q-210153 16.11-00372 is used for engines after 327Q-210152
	16.11-00506	1	Crankshaft Assembly—350Q, 350QA Series
11	16.11-00096	1	Flywheel Dowel Pin (Incl. in Crankshaft)
12	16.11-00028	1	Crankshaft Gear—307QL, 307QAL, 327QL, 327QAL, 350QL, 350QAL LH Rot.
13	16.11-00334	1	Crankshaft Sprocket—307Q, 307QA, 327Q, 327QA, 350Q, 350QA RH Rot.
14	16.11-00098	2	Crankshaft Gear or Sprocket Key
15	16.51-10026	2	Crankshaft Front Bearing Seal (RH Rot. only)
15	16.51-10016	2	Crankshaft Front Bearing Seal (LH Rot. only)

MAIN BEARINGS

16	16.11-00389	1	Main Bearing Set—Rear (Incl. Upper & Lower)
17	16.11-00327	4	Main Bearing Set—All except Rear (Upper & Lower)
17	16.11-00390	1	Main Bearing Set—Rear (Incl. Upper & Lower .001 US)
17	16.11-00391	1	Main Bearing Set—Rear (Incl. Upper & Lower .002 US)
17	16.11-00392	1	Main Bearing Set—Rear (Incl. Upper & Lower .010 US)
17	16.11-00393	1	Main Bearing Set—Rear (Incl. Upper & Lower .020 US)
17	16.11-00395	4	Main Bearing Set—All except Rear (Upper & Lower .001 US)
17	16.11-00396	4	Main Bearing Set—All except Rear (Upper & Lower .002 US)
17	16.11-00397	4	Main Bearing Set—All except Rear (Upper & Lower .010 US)
17	16.11-00398	4	Main Bearing Set—All except Rear (Upper & Lower .020 US)
	16.11-00375	4	Main Bearing Cap Bolt (2 in ea. main bearing cap)
	16.11-00376	6	Main Bearing Cap Stud (front, inter, Center & Rear)

FLYWHEEL, PULLEY & WATER PUMP DRIVE

18	16.11-08290	1	Flywheel & Ring Gear Assembly
19	16.11-00157	6	Attaching Bolt
20	16.11-00158	6	Lockwasher $\frac{1}{16}$ " Ext. Shkprf.
21	16.20-08292	1	Flywheel Pulley
22	16.30-08321	6	Flywheel & Pulley Retaining Bolt $\frac{1}{16}$ "—20 x 2 $\frac{1}{4}$ "
23	16.20-08313	1	Water Pump Drive Pulley
	16.47-06612	1	Pin-Water Pump Pulley to Flywheel Pulley
24	16.30-00078	4	Capscrew $\frac{5}{16}$ "—18 x 1 $\frac{3}{4}$ " Water Pump to Flywheel Pulley
25	16.42-00002	4	Lockwasher $\frac{5}{16}$ "
NOTE: When replacing the water pump drive pulley before serial numbers 307Q (102067) and 327Q (210370), the 16.47-06612 pin water pump pulley to flywheel pulley must be removed.			

DAMPER DRIVE HUB

26	16.71-07809	1	Damper Drive Hub—To Crankshaft
27	16.99-08334	1	Drive Plate Assembly (Y-12554)
28	16.43-00005	5	Special Lockwasher $\frac{1}{4}$ " External
28(a)	16.30-07392	5	Capscrew

Chris-Craft

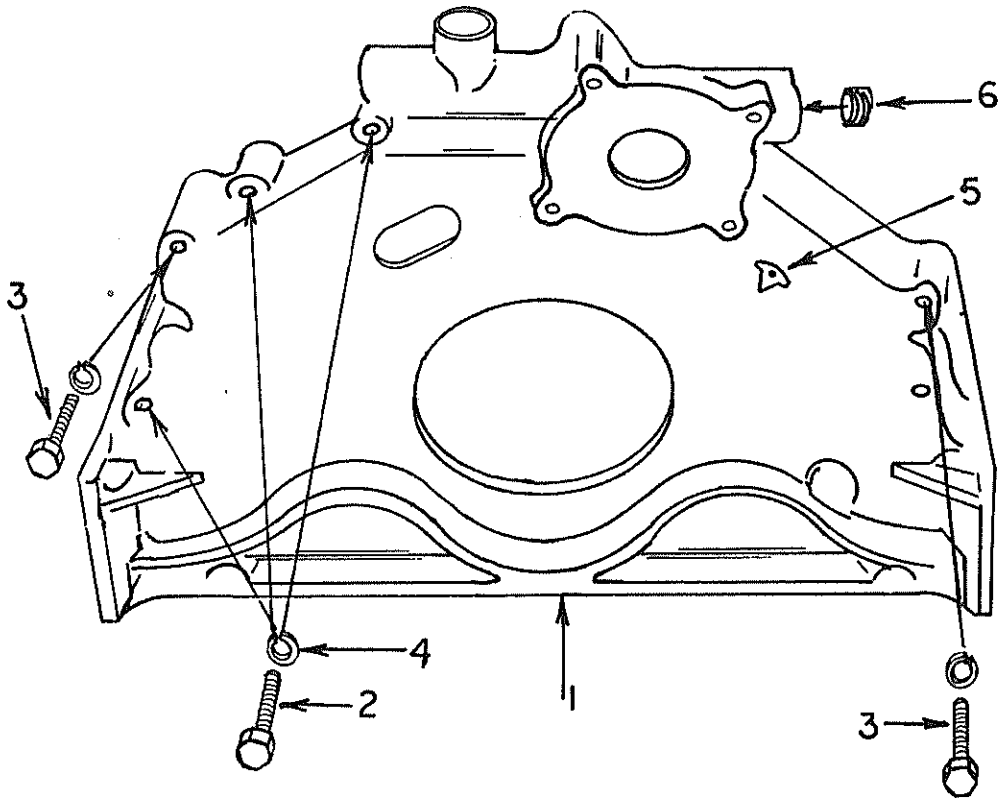

Code No.	Part No.	No. Req'd	Name
<u>FLYWHEEL COVER</u>			
1	16.20-08315	1	Flywheel Cover
2	16.30-00144	3	Capscrew $\frac{3}{8}$ "—16 x 2 $\frac{1}{4}$ "
3	16.30-00152	2	Capscrew $\frac{3}{8}$ "—16 x 2 $\frac{3}{4}$ "
4	16.42-00004	5	Lockwasher $\frac{3}{8}$ "
5	16.47-00008	1	Pin Ignition Timing Indicator
6	16.58-10168	1	Pipe Plug $\frac{3}{4}$ "—14 Brass

Chris-Craft

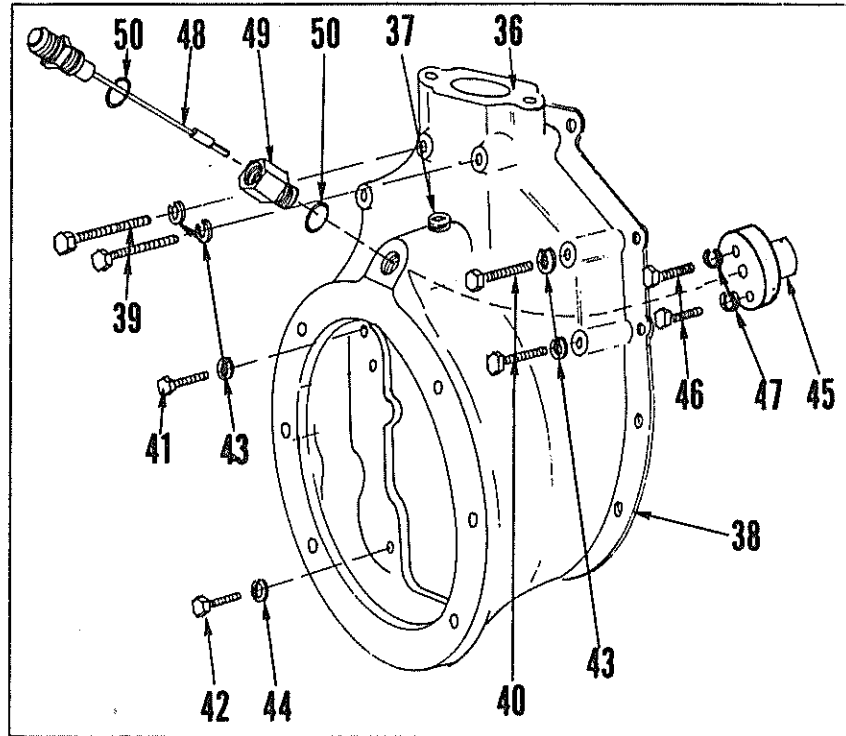

Code No.	Part No.	No. Req'd	Name
<u>TIMING CHAIN COVER</u>			
36	16.20-08263	1	Timing Chain Cover
37	16.58-10164	1	Pipe Plug Countersunk Head 1/2"—14 Brass
38	16.50-08254	1	Cylinder Block to Timing Chain Cover Gasket
39	16.30-00028	2	Capscrew 1/4"—20 x 2 1/4"
40	16.30-00020	4	Capscrew 1/4"—20 x 1 3/4"
41	16.30-00004	2	Capscrew 1/4"—20 x 3/4"
42	16.30-00124	9	Capscrew 3/8"—16 x 1"
43	16.42-00001	8	Lockwasher 1/4"
44	16.42-00004	11	Lockwasher 3/8"
	16.44-07630	2	Stud, Timing chain cover
	16.30-00126	2	Screw, cap 3/8—16 X 1-1/8"

TACHOMETER DRIVE ASSEMBLY

45	16.72-08298	1	Fuel Pump Drive Adapter
46	16.30-00078	3	Capscrew 5/16"—18 x 1 3/4"
47	16.43-00011	3	Toothlock Washer 5/16"
48	16.99-08278	1	Tachometer Drive Assembly
49	16.72-08374	1	Tachometer Drive Spacer
50	16.50-00166	2	Gasket (Between Spacer & Cover)
	16.72-08133	1	Tachometer Drive Cap

*Chris * Craft*®

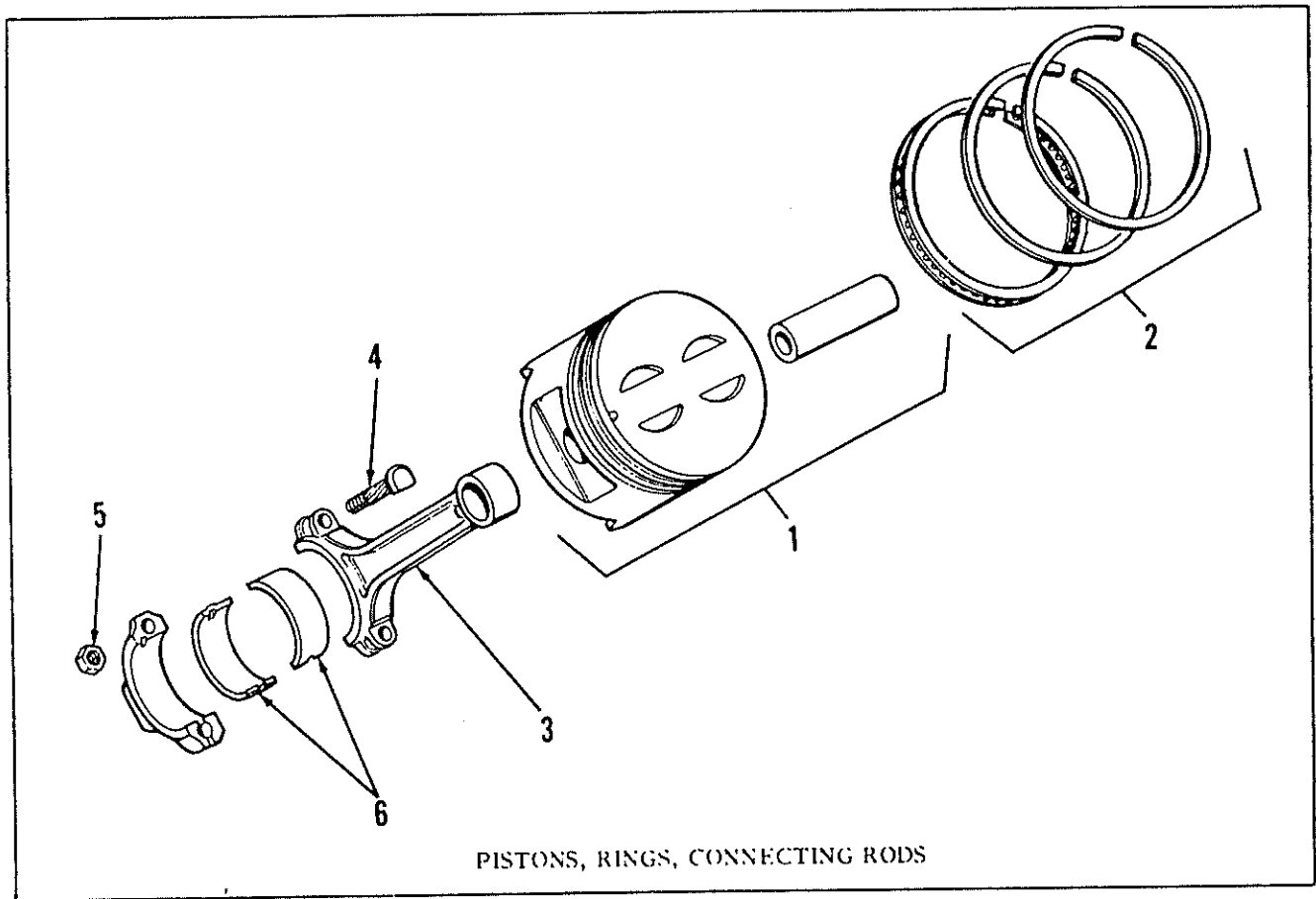

PISTONS, RINGS, CONNECTING RODS

Code No.	Part No.	No. Req'd.	Name
PISTONS AND RINGS			
1	16.11-00511	8	Piston & Pin Assembly—After Engine 350Q-220073
1	16.11-00352	8	Piston & Pin Assembly—Before Engine 307Q-102992
1	16.11-00533	8	Piston & Pin Assembly 307Q Series—After Engine 307Q-102991
	16.11-00531	8	Piston & Pin Assembly 350Q Series—Before Engine 350Q-220074
2	16.11-00383	1	Piston Rings—Complete Set 307Q
	16.11-00385	1	Piston Rings—Complete Set 307Q—.030 O.S.
	16.11-00356	8	Piston & Pin Assembly 327Q Series
	16.11-00235	1	Piston Rings—Complete Set 327Q STD
		1	Piston Rings—Complete Set 327Q .020 O.S. N/A-Sell .030-16.11-09388
	16.11-00388	1	Piston Rings—Complete Set 327Q .030 O.S.
	16.11-00386	8	Piston Rings (Std.) 1 Set per Piston
	16.11-00693	8	Piston Rings (.010 O.S.) 1 Set per Piston
	16.11-00694	8	Piston Rings (.030 O.S.) 1 Set per Piston
CONNECTING RODS			
3	16.11-00300	8	Connecting Rod Assembly (includes rod, bolts, cap & nuts)
4	16.11-00303	16	Connecting Rod Bolt
5	16.11-00304	16	Connecting Rod Nut
6	16.11-00305	8	Connecting Rod Bearing STD (includes upper & lower halves)
6	16.11-00306	8	Connecting Rod Bearing—.001 U.S. (includes upper & lower halves)
6	16.11-00380	8	Connecting Rod Bearing—.002 U.S. (includes upper & lower halves)
6	16.11-00381	8	Connecting Rod Bearing—.010 U.S.
6	16.11-00382	8	Connecting Rod Bearing—.020 U.S.

Code No.	Part No.	No. Req'd	Name
----------	----------	-----------	------

OIL PAN, DIPSTICK ASSEMBLY & OIL PUMP

16.20-08208		1	Oil Pan
16.51-17639		1	Oil Pan Seal, Front
16.50-08230		1	Oil Pan Gasket, Left
16.50-08231		1	Oil Pan Gasket, Right
16.30-00008		11	Capscrew ¼"—20 x 1"
16.30-00020		3	Capscrew ¼"—20 x 1¾"
16.30-00078		2	Capscrew ⅝"—18 x 1¾"
16.30-00086		2	Capscrew ⅝"—18 x 2¼"
16.42-00001		14	Lockwasher ¼"
16.42-00002		4	Lockwasher ⅝"
16.70-08234		1	Oil Pan Baffle
16.39-08394		6	Locknut ⅜"—16 (Oil Pan Baffle to Main Bearing Cap Studs)
16.95-08274		1	Oil Pick-Up Assembly (Consist of the following two parts:)
16.70-08273		1	Oil Pick-Up Support Bracket
16.95-08233		1	Oil Pick-Up Screen & Tube Ass'y. (Consist of the following two parts):
16.95-08232		1	Oil Pick-Up Screen Assembly, only
16.57-58432		1	Oil Pick-Up Tube
16.58-10057		2	Elbow ⅜" NPT—Between Oil Pick-Up Tube & Oil Pump
16.57-08397		1	Oil Level Dipstick Tube Ass'y. (Consist of the following two parts):
16.57-06494		1	Oil Level Dipstick Tube (Not Stocked)
16.72-08236		1	Oil Level Dipstick Tube Collar (Not Stocked)
16.50-08510		2	"O" Ring (with Plug)
16.72-08285		1	Plug, Oil Level Dipstick Tube in Opposite Side from Dipstick Assembly
16.99-00008		1	Dipstick Tube Clamp
16.30-00120		1	Capscrew ⅝"—16 x ¾"—Attach clamp to cylinder block
16.42-00004		1	Lockwasher ⅜"
16.72-08238		1	Oil Level Dipstick

OIL PUMP & SCREEN ASSEMBLY

16.11-00070		1	Oil Pump & Screen Assembly
16.11-00274		1	Attaching Bolt ⅝"—14 x 2"
16.11-00011		1	Oil Pump Shaft Assembly (also drives dist.)

Chris-Craft®

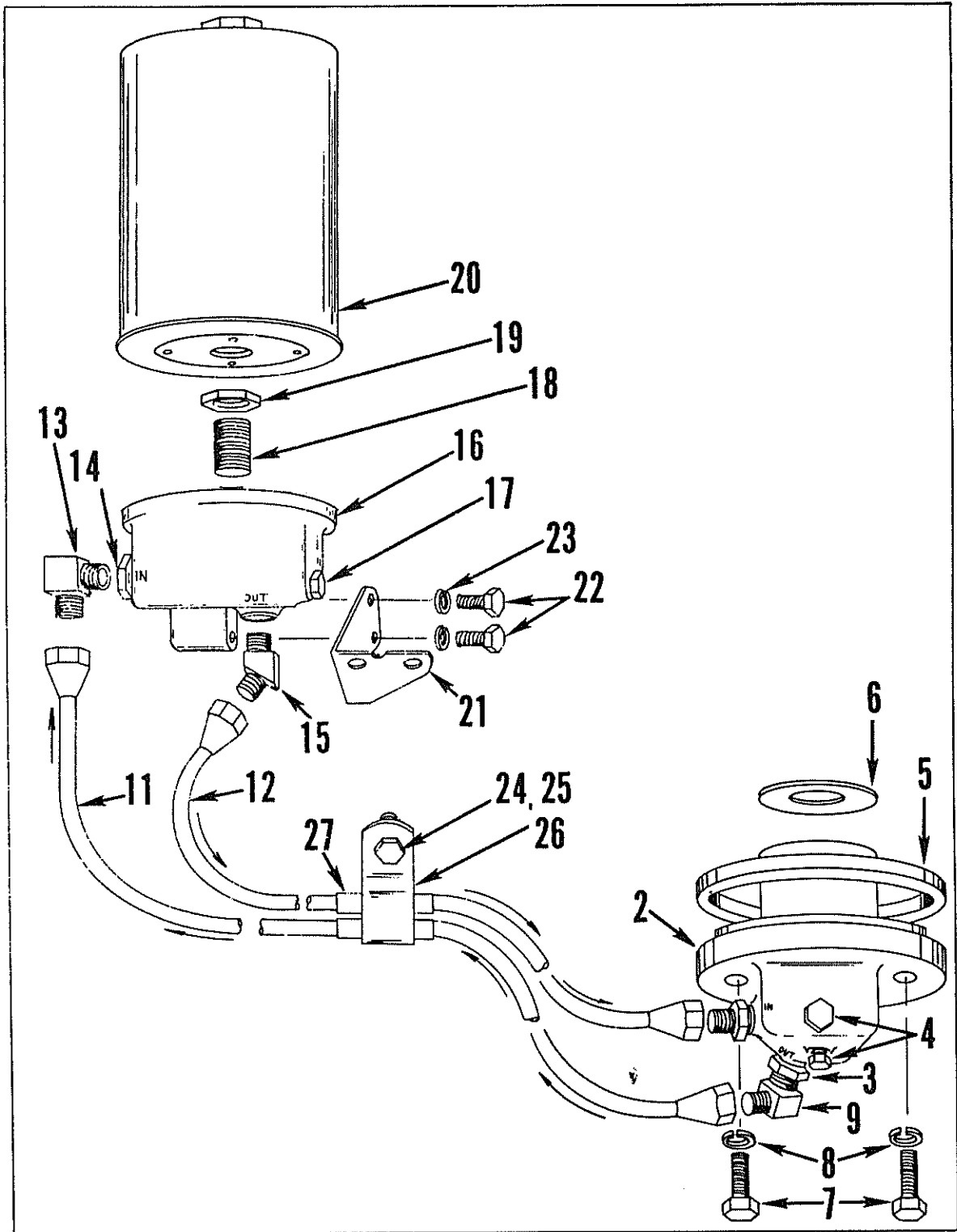

Chris-Craft

Code No.	Part No.	No. Req'd	Name
<u>OIL FILTER ASSEMBLY</u>			
2	16.95-08634	1	Oil Filter Adapter—To Cylinder Block
	16.99-08126	1	By-Pass Valve Assembly
3	16.58-10225	1	Reducer Bushing $\frac{3}{4}$ " MPT x $\frac{3}{8}$ " FPT
4	16.58-10151	2	Hex Head Pipe Plug $\frac{1}{8}$ "—27 NPT
5	16.50-08356	1	Oil Filter Adapter Ring Gasket
6	16.50-08351	1	Oil Filter Adapter to Cylinder Block Gasket
7	16.30-00082	2	Capscrew $\frac{5}{16}$ "—18 x 2"
8	16.41-00002	2	Washer Flat $\frac{5}{16}$ "
9	16.59-10580	1	Elbow $\frac{1}{2}$ "—T x $\frac{3}{8}$ " MPT—Adapter Out
10	16.59-10117	1	Connector $\frac{1}{2}$ "—T x $\frac{3}{8}$ " MPT—Adapter In
11	16.57-58420	1	Oil Line—Adapter to Filter Base
12	16.57-58421	1	Oil Line—Filter Base to Adapter
13	16.59-10580	1	Elbow— $\frac{1}{2}$ " T x $\frac{3}{8}$ " MPT
14	16.58-10213	1	Bushing $\frac{3}{8}$ " FPT x $\frac{1}{2}$ " MPT—Into Filter Base
15	16.59-17989	1	Elbow, 45 $\frac{1}{2}$ " T x $\frac{3}{8}$ " MPT—Filter Base Outlet
16	16.20-08330	1	Oil Filter Base
17	16.58-10151	1	Pipe Plug $\frac{1}{8}$ "—27
18	16.72-08127	1	Nipple $\frac{1}{16}$ "—16—Attach Oil Filter To Base
19	16.72-08128	1	Hex Nut $\frac{1}{16}$ "—16
20	16.81-08130	1	Oil Filter Assembly
21	16.70-08418	1	Bracket—Oil Filter Base to Intake Manifold
22	16.30-00120	2	Capscrew $\frac{3}{8}$ "—16 x $\frac{3}{4}$ "—Attach Filter Base to Manifold Bracket
23	16.42-00004	2	Lockwasher $\frac{3}{8}$ "
24	16.30-00132	1	Capscrew $\frac{3}{8}$ "—16 x 1 $\frac{1}{2}$ "
25	16.42-00004	1	Lockwasher $\frac{3}{8}$ "
26	16.99-00074	1	Tube Clamp
27	16.57-08426	1	Spacer—Between Clamp & Cylinder Block

NOTE: The last four (4) parts support and attach oil lines to the cylinder block.

Chris-Craft

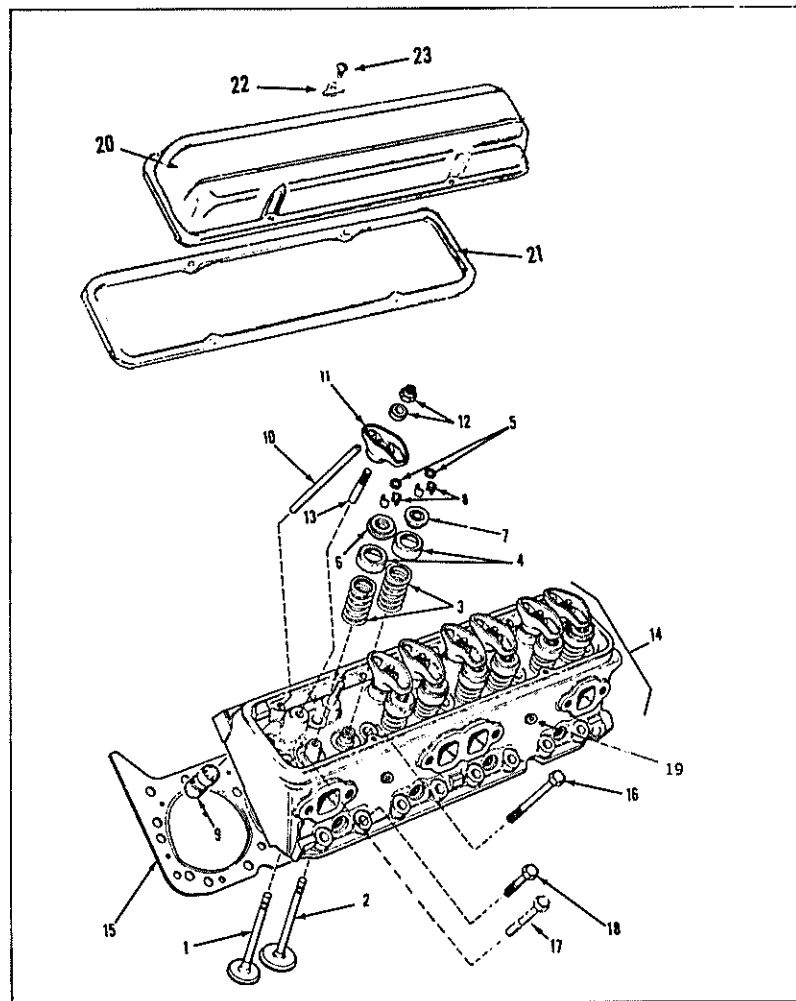

CYLINDER HEAD & VALVES

Code No.	Part No.	No. Req'd.	Name
			VALVES
1	16.11-00535	8	Exhaust Valve (307Q Series)
	16.11-00255		NOTE: 16.11-00255 is used before engine 307Q-102992 307Q & 350Q
1	16.11-00340	8	Exhaust Valve (327Q Series)
			NOTE: Oversize stems available:
2	16.11-00530	8	Intake Valve (307Q Series)
			NOTE: 16.11-00148 is used before engine 307Q-102992 16.11-00530 is used after engine 307Q-102991 & 350Q
2	16.11-00360	8	Intake Valve (327Q Series)
			NOTE: Oversize stems available
3	16.11-00322	8	Valve Spring & Damper Assembly
4	16.11-00153	16	Valve Stem Oil Shield
5	16.11-00152	16	Valve Stem Oil Seal
6	16.11-00735	8	Exhaust Valve Rotator Assembly
7	16.11-00273	8	Intake Valve Spring Cap
8	16.11-00433	32	Valve Stem Key
	16.11-00703	8	Valve Spring & Damper Assembly—Exhaust 307Q

Code No.	Part No.	No. Req'd	Name
<u>VALVE LIFTERS & ROCKER ARMS</u>			
9	16.11-00349	16	Valve Lifter Assembly—Hydraulic NOTE: It is very important that special camshaft lubricant be applied liberally to prevent damaging camshaft lobes, when new camshaft or valve lifters are installed. This lubricant can be ordered from Chris-Craft using part number 56.00-20630.
10	16.11-00038	16	Push Rod
11	16.11-00014	16	Valve Rocker Arm
12	16.11-00043	16	Nut, Valve Rocker, Ball Combination
13	16.11-00227	16	Rocker Arm Stud $\frac{3}{8}$ "—24 x 2 $\frac{1}{2}$ "—.003 O.S.
	16.11-00228	16	Rocker Arm Studs .013 O.S.

CYLINDER HEAD

14		2	Cylinder Head—Complete with Valves (307Q Series) N/A
14	16.11-00316	2	Cylinder Head—With Studs only (307Q Series) Before Engine 307Q-102992
14	16.11-00374	2	Cylinder Head—Complete with Valves (327Q Series)
14	16.11-00343	2	Cylinder Head—With Studs only (327Q Series)
15	16.50-00147	2	Cylinder Head Gasket (Stainless Steel)
16	16.11-00010	14	Cylinder Head Bolt—Long
17	16.11-00022	4	Cylinder Head Bolt—Medium
18	16.11-00003	16	Cylinder Head Bolt—Short
19	16.58-10164	4	Pipe, Plug, Countersunk Head $\frac{1}{2}$ "—14 Brass
	16.11-00839	2	Head, Cylinder Assembly complete w/valves—350Q Series
	16.11-00373		
	16.11-00726	2	Cylinder Heads w/Studs only—307Q & 350Q Series CN-222 & 223 3998993 6272070

VALVE COVER

NOTE: Install the valve cover with the oil filter cap opening towards the rear on models 307Q and 327Q and the cover with the opening towards the front on models 307QL and 327QL.

20	16.11-00660	1	Valve Cover, LH. Sell 16.11-00659
	16.11-00659	1	Valve Cover, RH. Sell 16.11-00659 Series replacement No.6272227
	16.11-00532	1	Oil Filter Cap (In LH Valve Cover)
21	16.50-00161	2	Valve Cover Gasket
22	16.11-00259	8	Valve Cover Reinforcement
23	16.11-00358	8	Valve Cover Bolt
	16.92-07761	1	Fuel Decal
	16.92-07601	2	Decal, Engine Rotation (307QL, 327QL, 350QL)
	16.92-08280	2	HP & Model Decal (307Q - 307QL)
	16.92-08239	2	HP & Model Decal (327Q - 327QL)
	16.92-08434	2	HP & Model Decal (307QA - 307QAL)
	16.92-08435	2	HP & Model Decal (327QA - 327QAL)
	16.92-08661	2	HP & Model Decal (350QL)
	16.92-08662	2	HP & Model Decal (350Q)
	16.92-08663	2	HP & Model Decal (350QAL)
	16.92-08664	2	HP & Model Decal (350QA)

Chris-Craft

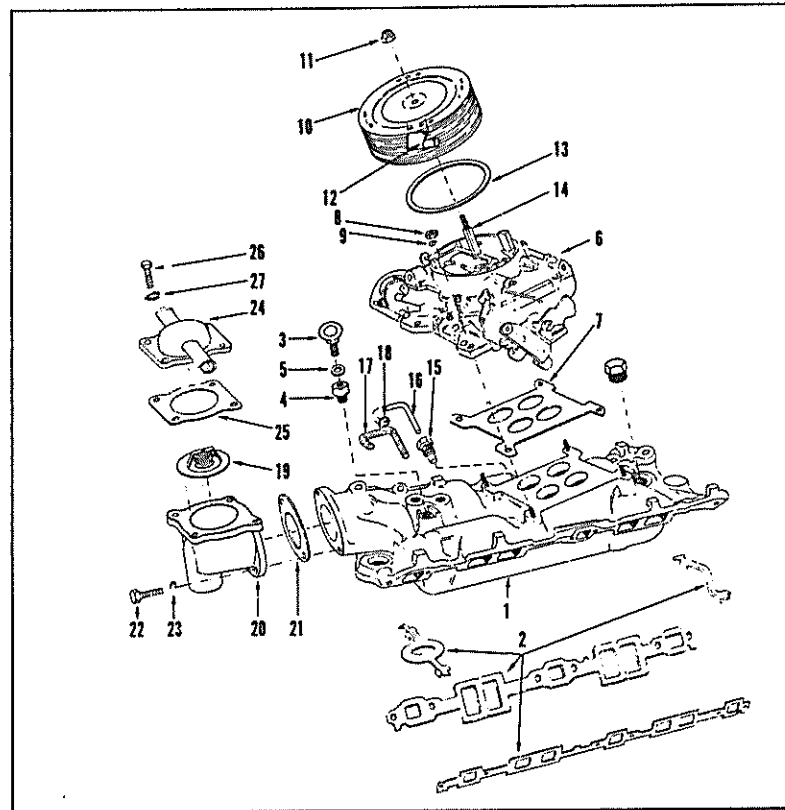

Code No.	Part No.	No. Req'd	Name
<u>INTAKE MANIFOLD, FRONT LIFTING RING & THROTTLE BRACKET</u>			
1	16.95-08299	1	Intake Manifold Ass'y (Incl. the following 4 parts)
	16.20-08608	1	Intake Manifold
	16.44-06310	4	Studs
	16.58-10167	1	Pipe Plug 3/4"—14 NPT (Aft of Carburetor to drain Manifold)
	16.74-10007	3	Cup Plug (One aft of lifting ring & two aft of carburetor)
2	16.50-00176	1	Intake Manifold Gasket Set
	16.30-00128	5	Capscrew 3/8"-16 x 1 1/4"
	16.30-00148	2	Capscrew 3/8"-16 x 2 1/2", 3/8"-16 x 1 3/8"
	16.30-00130	1	Capscrew 3/8"-16 x 3 1/2"
	16.30-00132	2	Capscrew 3/8"-16 x 1 1/2" (Thru Oil Filter Base Bracket)
	16.42-00004	12	Lockwasher 3/8"
	16.70-08424	1	Throttle Bracket

Code No.	Part No.	No. Req'd	Name
<u>CARBURETOR ASSEMBLY & FLAME ARRESTOR</u>			
6	16.82-48688	1	Carburetor Assembly—Carter Old #16.82-40008 Disc. when out
	16.96-00087	1	Carburetor Repair Kit
	16.70-07852	1	Throttle Lever
7	16.50-08352	1	Carburetor to Intake Manifold Gasket
8	16.36-00003	4	Hex Nut $\frac{1}{16}$ "—24
9	16.42-00002	4	Lockwasher $\frac{1}{16}$ "
10	16.82-00036	1	Flame Arrestor—Consisting of the following five parts:
11	16.32-00128	1	Round Head Screw #6—32 x 2"
12	16.99-00073	1	Tube & Bracket Assembly
	16.41-00027	1	Washer $\frac{1}{4}$ " x $\frac{1}{2}$ " x $\frac{1}{32}$ "
	16.41-00028	1	Washer $\frac{3}{4}$ " x $\frac{3}{8}$ " x .050"
	16.39-00013	1	Hex Locknut #6—32
13	16.50-08361	1	Flame Arrestor to Carburetor Gasket
14	16.44-08360	1	Flame Arrestor Stud
	16.39-00010	1	Flame Arrestor Stud Locknut
15	16.72-36264	1	Automatic Choke Heater Stove
16	16.95-08511	1	Automatic Choke Heater Tube $\frac{1}{4}$ " OD x 12"
17	16.57-97584	1	Automatic Choke Heater Tube Cover
18	16.59-10705	1	Nut—Heater Tube to Carburetor

THERMOSTAT & HOUSING ASSEMBLY

19	16.99-08329	1	Thermostat
20	16.20-08495	1	Thermostat Housing
21	16.50-08317	1	Thermostat Housing to Intake Manifold Gasket
22	16.30-00066	2	Capscrew $\frac{1}{16}$ "—18 x 1"
23	16.42-00002	2	Lockwasher $\frac{1}{16}$ "
24	16.20-08496	1	Thermostat Housing Cap
25	16.50-08333	1	Thermostat Housing Cap Gasket
26	16.30-00004	4	Capscrew $\frac{1}{4}$ "—20 x $\frac{3}{4}$ "
27	16.42-00001	4	Lockwasher $\frac{1}{4}$ "
	16.42-00008	1	Lockwasher $\frac{1}{2}$ " x .171 x .125"

Chris-Craft

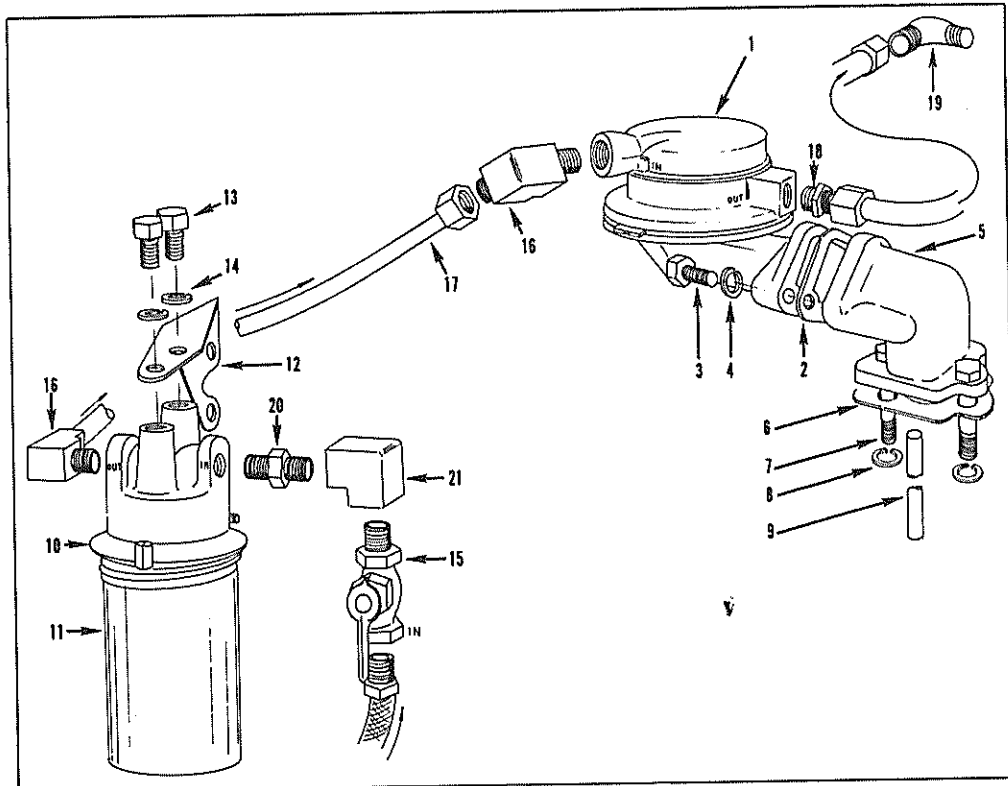
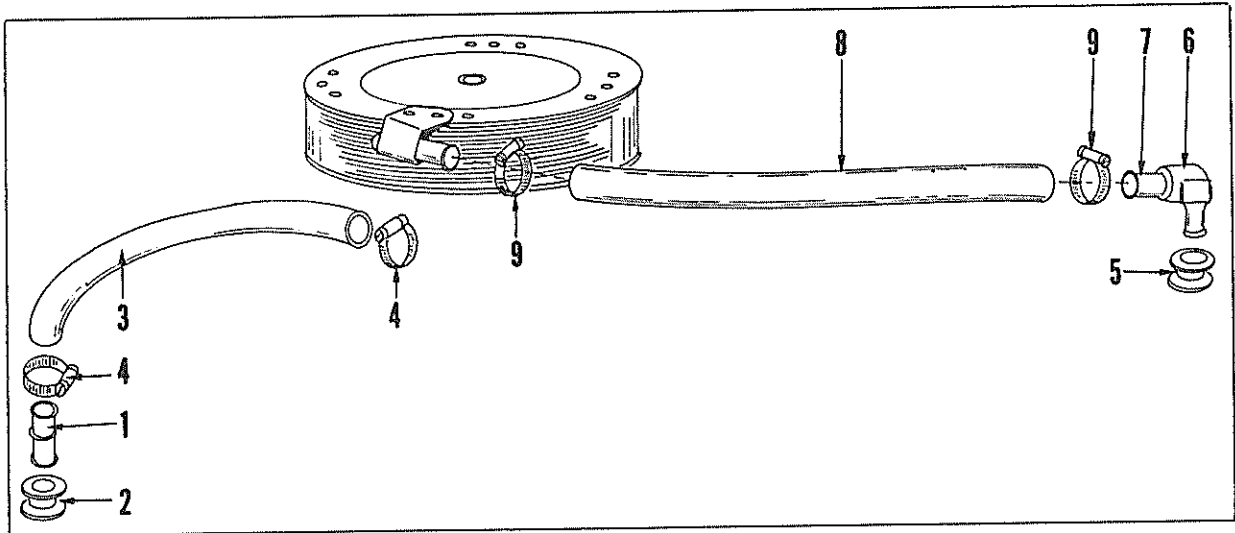

Code No.	Part No.	No. Req'd.	Name
CRANKCASE VENTILATION SYSTEM			
1	16.99-00072	1	Vent Valve Assembly (in LH Valve Cover)
2	16.11-00544	1	Grommet (in LH Valve Cover)
3	16.54-08362	1	Hose 3/8" ID (from LH Valve Cover to Carburetor)
4	16.55-38391	2	Hose Clamp
5	16.51-37975	1	Grommet (in RH Valve Cover)
6	16.58-10221	1	Elbow 1/2" H X 3/8" FPT
7	16.58-17118	1	Hose Nipple 3/8" MPT X 1/4"
8	16.54-10054	1	Hose 5/8" ID X 12" (RH Valve Cover to Flame Arrestor)
9	16.55-37158	2	Hose Clamp
	16.95-08672	1	Hose Assembly, Crankcase Vent System with Connector
FUEL PUMP & FILTER ASSEMBLY			
1	16.83-07004	1	Fuel Pump, Carter
2	16.50-00074	1	Gasket, Fuel Pump Mounting
3	16.30-00132	2	Capscrew 3/8"—16 X 1 1/2"
4	16.42-00004	2	Lockwasher 3/8"
4	16.41-00006	2	Plain Washer 25/64"
	16.21-05938	1	Fuel Pump Mounting Flange Cover (LH Rear of Block)
	16.50-05756	1	Fuel Pump Mounting Flange Cover Gasket
	16.30-00122	1	Capscrew 3/8"—16 X 7/8"
	16.42-00004	2	Lockwasher 3/8" (One at Stud—One under capscrew)
	16.30-00002	2	Capscrew 1/4"—20 X 5/8"
	16.41-00002	2	Plain Washer 9/32" X 5/8" X 1/16"
	16.42-00001	2	Lockwasher 1/4"
5	16.20-08293	1	Fuel Pump Mounting Adapter
6	16.50-08294	1	Fuel Pump Adapter to Timing Chain Cover Gasket
7	16.30-00064	2	Capscrew 5/16"—18 X 7/8"
8	16.42-00002	2	Lockwasher 5/16"
9	16.72-08300	1	Fuel Pump Push Rod 5 1/2" long—
10	16.81-00014		Fuel Filter Assembly
			1-16.20-00090 Bracket
			2-16.30-00062 Capscrew 5/16—18 3/4
			2-16.36-00002 Nut 5/16—18
11	16.81	1	Fuel Filter Element
12	16.70-08354	1	Fuel Filter Bracket—Attaches to the left side of the Cylinder Block Water Inlet Fitting shown in Circulating Water Pump System
13	16.30-00061	2	Capscrew 5/16"—24 X 5/8" Filter to Bracket
14	16.42-00002	2	Lockwasher 5/16"
15	16.99-00033	1	Fuel Shut-Off Valve 1/4"—Fuel Filter Inlet
16	16.59-00068	2	Elbow 3/8" T X 1/4" MPT—Fuel Filter Outlet & Fuel Pump Inlet
			NOTE: The following part used before serial numbers 307Q (102130) and 327Q (210542)
17	16.57-58376	1	Line from Pump to Carburetor 5/16" X 8"
	16.57-58375	1	Line from Fuel Filter to Fuel Pump
			NOTE: The following part used after serial numbers 307Q (102129) and 327Q (210541)
17A	16.57-58513	1	Line, Fuel Filter to Fuel Pump
18	16.59-00129	1	Connector, Fuel Pump Outlet 5/16" X 1/8"
19	16.59-06670	1	Elbow 5/16" T X 1/8" MPT—Carburetor Unit
20	16.58-10112	1	Nipple, Hex 1/4"—18 NPT
21	16.58-10211	1	Elbow, 90 X 1/4"—NPT

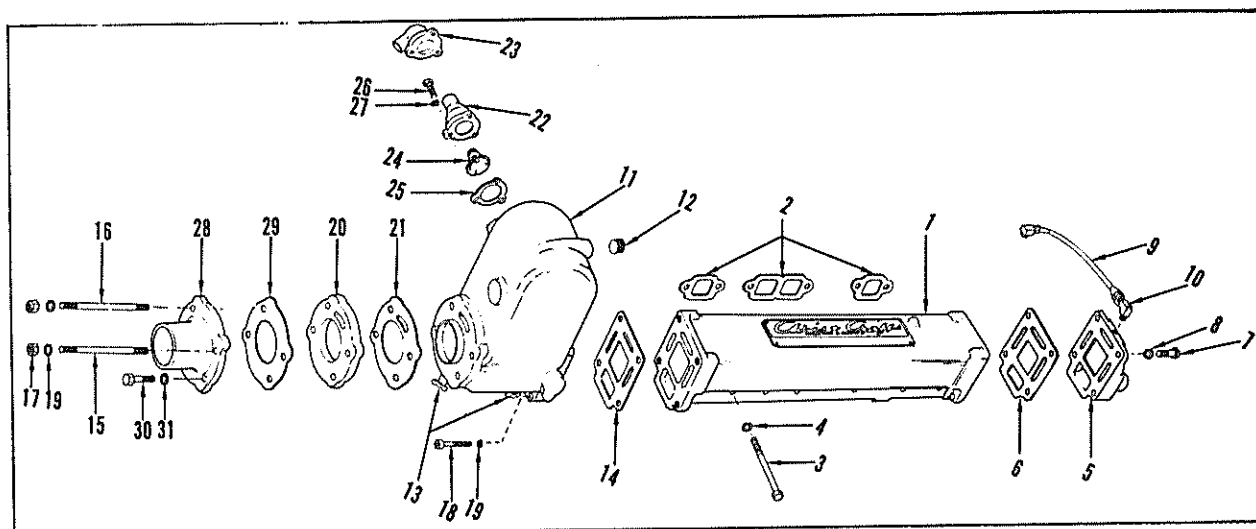
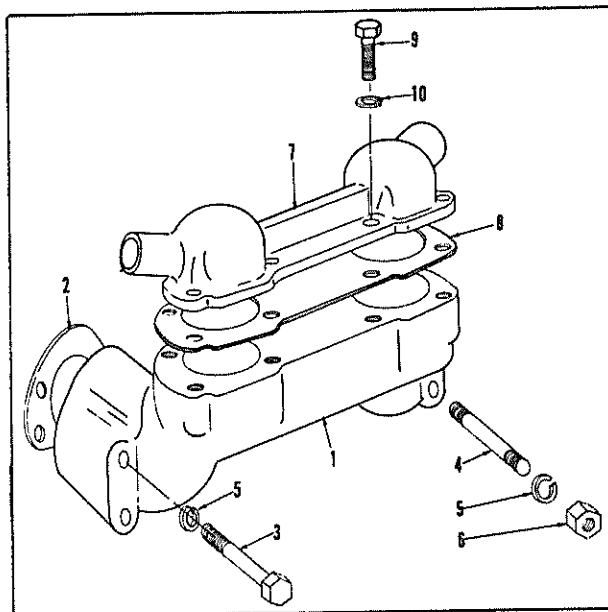

Code No.	Part No.	No. Req'd	Name
	CYLINDER BLOCK WATER INLET FITTING		
1	16.20-08318	1	Cylinder Block Water Inlet Fitting (Rear of Block)
2	16.50-00078	1	Inlet Fitting to Cylinder Block Gasket Left (shown)
	16.50-00077	1	Inlet Fitting to Cylinder Block Gasket Right
3	16.30-00172	3	Capscrew $\frac{3}{8}$ "—16 x 4"
4	16.44-07665	1	Stud $\frac{3}{8}$ " x 4 $\frac{1}{2}$ "—Lower RH Hole into Block (Oil Cooler Bracket Attaching)
5	16.42-00004	4	Lockwasher $\frac{3}{8}$ "
6	16.36-00005	1	Nut $\frac{3}{8}$ "—24
7	16.20-08320	1	Water Inlet Fitting Cap
8	16.50-08319	1	Cap to Water Inlet Fitting Gasket
9	16.30-00006	7	Capscrew $\frac{1}{4}$ "—20 x $\frac{7}{8}$ "
10	16.42-00001	7	Lockwasher $\frac{1}{4}$ "

Code No.	Part No.	No. Req'd	Name
<u>EXHAUST MANIFOLD — HEADERS & RISERS</u>			
1	06.20-07686	2	Exhaust Manifold
2	16.50-05748	2	Exhaust Manifold Gasket Set (Manifold to Cylinder Head)
3	16.30-00172	12	Capscrew $\frac{3}{8}$ "—16 x 4" (Manifold to Cylinder Head)
4	16.42-00004	12	Lockwasher $\frac{3}{8}$ "
	16.20-08286	1	Exhaust Manifold Header—Left Hand
5	16.20-08287	1	Exhaust Manifold Header—Right Hand
6	16.50-05944	2	Header to Exhaust Manifold Gasket
7	16.30-00124	6	Capscrew $\frac{3}{8}$ "—16 x 1 $\frac{1}{8}$ "
8	16.30-00144	1	Capscrew $\frac{3}{8}$ "—16 x 2 $\frac{1}{4}$ " (Top Outside Plate of Left Header)
	16.30-00558	1	Capscrew
8	16.42-00004	8	Lockwasher $\frac{3}{8}$ "
9	16.57-58430	2	Vent Line—Exhaust Headers to Intake Manifold
10	16.59-10227	4	Elbow $\frac{3}{16}$ " T x $\frac{1}{8}$ " MPT
11	16.20-08288	1	Exhaust Manifold Riser—Left Hand
	16.58-10164	1	Pipe Plug $\frac{1}{2}$ "—14 (In LH Riser Only Without V-Drive)
11	16.20-08289	1	Exhaust Manifold Riser—Right Hand
12	16.58-10168	2	Pipe Plug $\frac{3}{4}$ " NPT (One in each riser)
	16.58-10160	1	Pipe Plug $\frac{3}{8}$ "—18
	16.74-10017	2	Cup Plug (One in each riser)
13	16.58-17982	4	Drain Valve $\frac{1}{4}$ " (Two in each riser)
14	16.50-05944	2	Riser to Exhaust Manifold Gasket
15	16.44-37595	2	Stud $\frac{3}{8}$ " x 9 $\frac{1}{4}$ " (riser to Exhaust Manifold—Top outside holes)
16	16.44-38383	2	Stud $\frac{3}{8}$ " x 9 $\frac{1}{2}$ " (riser to Exhaust Manifold—Top inside holes)
17	16.36-30000	4	Hex Nut $\frac{3}{8}$ "—24
18	16.30-00449	4	Socket Head Capscrew $\frac{3}{8}$ "—16 x 2 $\frac{1}{4}$ " (Bottom Holes)
19	16.42-00004	8	Lockwasher $\frac{3}{8}$ "
20	16.20-07593	2	Exhaust Elbow Deflector
21	16.50-07596	2	Riser to Exhaust Deflector—Gasket
22	16.22-07532	1	Pressure Relief Valve Housing
23	16.22-07640	1	Pressure Relief Valve Housing
24	16.99-07346	1	Pressure Relief Valve Assembly
25	16.50-07290	1	Gasket—Pressure Relief Valve Housing
26	16.32-40001	3	Machine Screw $\frac{1}{4}$ "—20 x $\frac{7}{8}$ "
27	16.50-00073	3	Gasket
	16.42-00001	2	Lockwasher $\frac{1}{4}$ " (Used with two screws that attach Terminal Block Bracket to Housing)

EXHAUST ELBOWS

28	16.20-07605	2	Exhaust Elbow—Straight 2 $\frac{1}{2}$ " ID Hose
	04.31-68933	2	Exhaust Elbow—Angle 2 $\frac{1}{2}$ " ID Hose
29	16.50-07597	2	Gasket—Elbow to Riser
30	16.30-00136	4	Capscrew $\frac{3}{8}$ "—16 x 1 $\frac{3}{4}$ "
31	16.42-00004	4	Lockwasher $\frac{3}{8}$ "

*Chris * Craft*

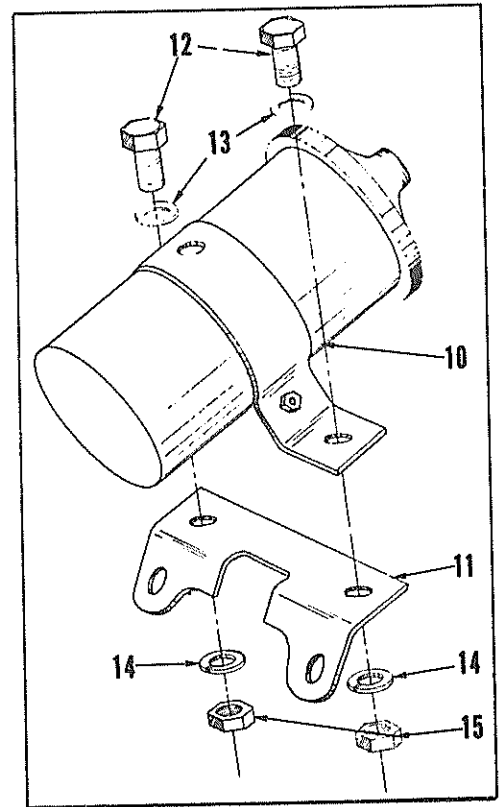
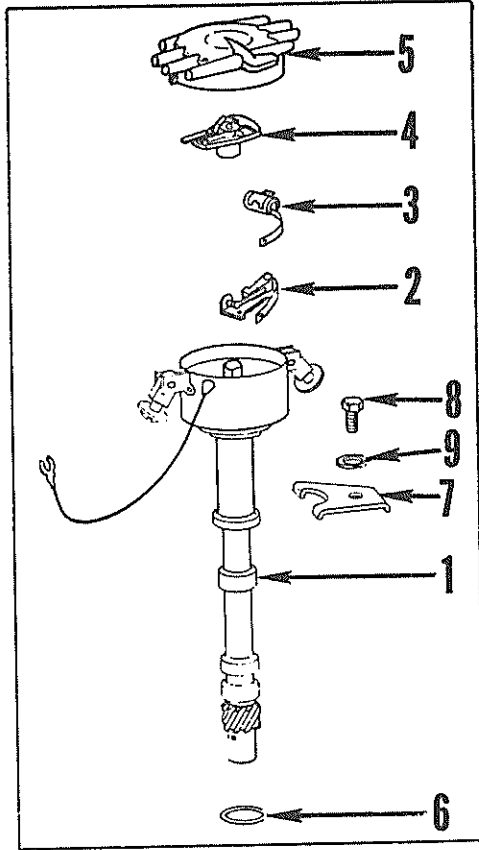

Code No.	Part No.	No. Req'd	Name
IGNITION DISTRIBUTOR			
1	16.64-00041	1	Ignition Distributor Assembly
2	16.69-00039	1	Ignition Points
3	16.69-00040	1	Condensor
4	16.69-00042	1	Rotor
5	16.69-00100	1	Ignition Distributor Cap
6	16.50-00162	1	Gasket—Distributor to Intake Manifold
	16.51-00018	1	"O" Ring
NOTE: The following part used before 307Q-102237, 327Q-210864			
7	16.70-08479	2	Hold Down Clamp
NOTE: The two (2) following parts used after 307Q-102236, 327Q-210863			
	16.70-08479	1	Hold Down Clamp
	16.41-00004	1	Washer
8	16.30-00070	1	Capscrew $\frac{5}{16}$ "—18 x $1\frac{1}{4}$ "
9	16.42-00002	1	Lockwasher $\frac{5}{16}$ "

Code No.	Part No.	No. Req'd	Name
<u>IGNITION COIL ASSEMBLY & BRACKET</u>			
10	16.64-00034	1	Coil, Ignition
11	16.95-08487	1	Coil Bracket—Attaches to left exhaust manifold header
12	16.30-00001	2	Capscrew ¼"—28 x ½" Coil to Bracket
13	16.41-00002	2	Washer ⅜"
14	16.42-00001	2	Lockwasher ¼"
15	16.36-00001	2	Hex Nut ¼"—28

SPARK PLUGS & CABLES

16.62-00004	8	Spark Plug—Champion RBL-9Y Eff Engine 350Q-22046
16.62-06256	8	Spark Plug—Champion UJ-6
16.62-08737	8	Spark Plug—AC MR43T 71 Model
16.63-08400	1	Coil to Distributor Cable
16.63-08698	1	Spark Plug Cable—Cyl. #1 (RH & LH Rot.)
16.63-08693	1	Spark Plug Cable—Cyl. #2, #3, #5, #7 (RH Rot.) #8 (LH Rot.)
16.63-08698	1	Spark Plug Cable—Cyl. #2 (LH Rot.)
16.63-08699	1	Spark Plug Cable—Cyl. #3 (LH Rot.), Cyl. #4 (RH Rot. and LH Rot.)
16.63-08693	1	Spark Plug Cable—Cyl. #5 (LH Rot.)
16.63-08694	1	Spark Plug Cable—Cyl. #6 (RH Rot.)
16.63-08692	1	Spark Plug Cable—Cyl. #6, #7 (LH Rot.)
16.63-08691	1	Spark Plug Cable—Cyl. #8 (RH Rot.)
16.11-00060	2	Separator
16.11-00059	2	Separator
16.92-07557	1	Decal, Cyl. #1
16.92-07558	1	Decal, Cyl. #2
16.92-07559	1	Decal, Cyl. #3
16.92-07560	1	Decal, Cyl. #4
16.92-07561	1	Decal, Cyl. #5
16.92-07562	1	Decal, Cyl. #6
16.92-07563	1	Decal, Cyl. #7
16.92-07564	1	Decal, Cyl. #8
16.92-08656	1	Decal, Distributor
16.92-08657	1	Decal, Distributor
16.63-08739	1	Complete Ignition Cable Set 307Q, 327Q & 350Q RH
16.63-08740	1	Complete Ignition Cable Set 307QL, 327QL & 350QL LH

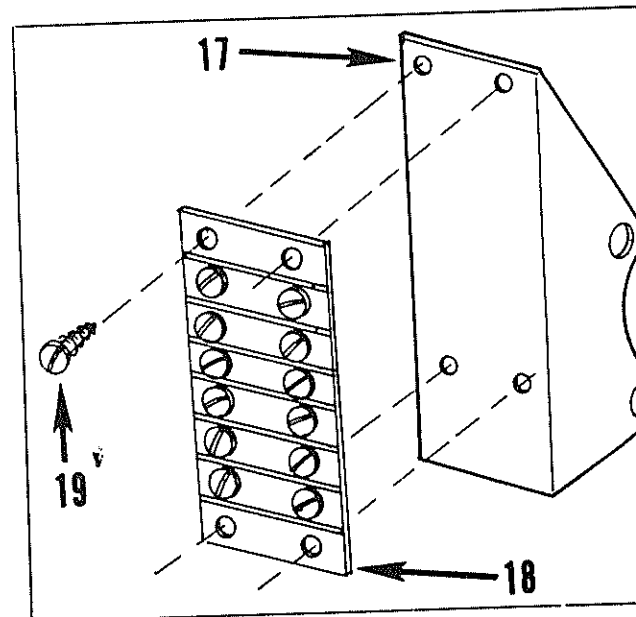
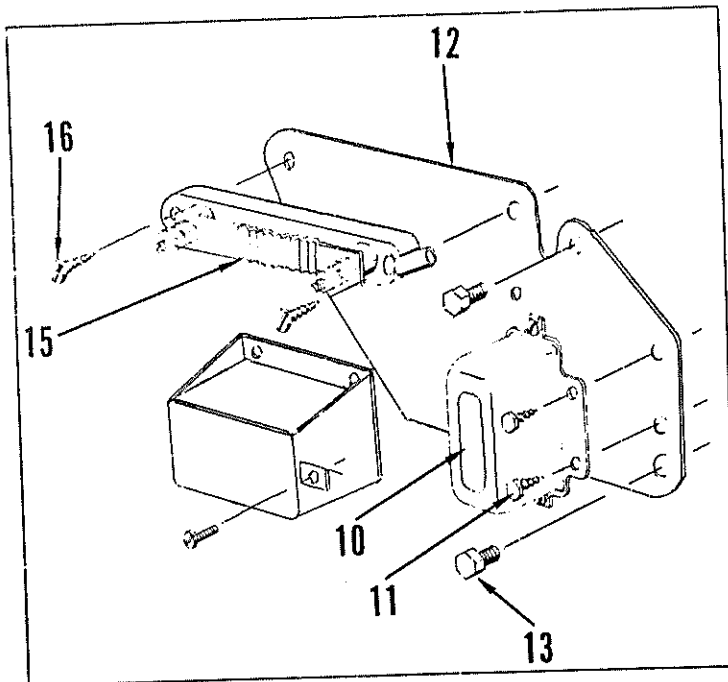
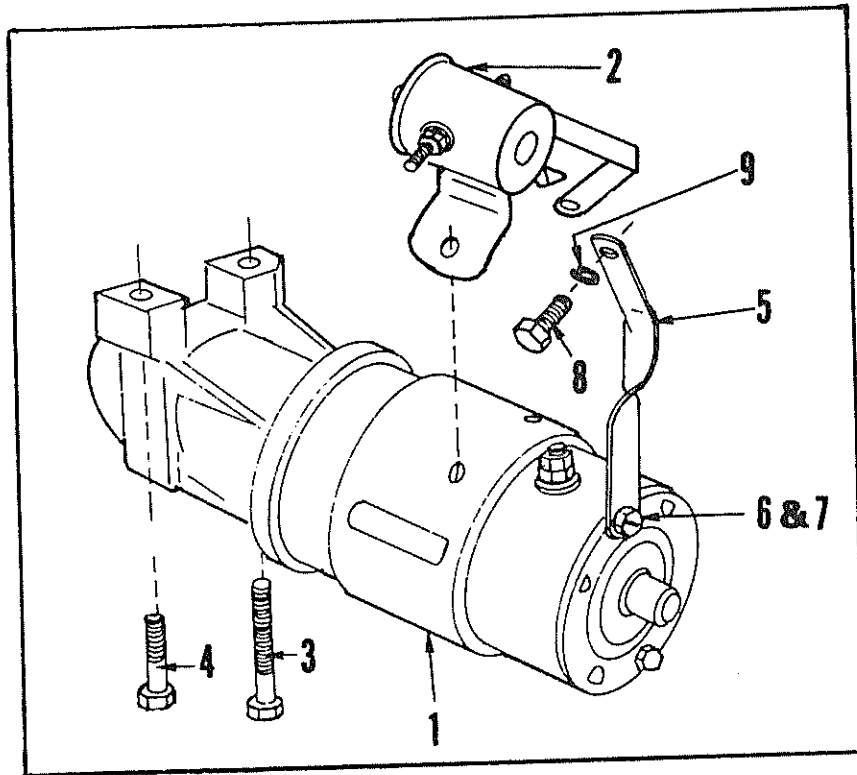

Code No.	Part No.	No. Req'd	Name
----------	----------	-----------	------

STARTING MOTOR

The following parts are used only on engines equipped with Prestolite starters.

1	16.61-00042	1	Starting Motor RH Rot
1	16.61-00043	1	Starting Motor LH Rot
2	02.19-00016	1	Solenoid Prestolite
3	16.11-00346	1	Bolt—Inboard
4	16.11-00347	1	Bolt—Outboard
5	16.70-08429	1	Support Bracket
6	16.36-00000	1	Hex Nut ¼"—20 Attaches bracket to starting motor stud
7	16.42-00001	1	Lockwasher ¼"
8	16.30-00058	1	Capscrew ⅝"—18 x ½"—Bracket to cylinder block
9	16.42-00002	1	Lockwasher ⅝"

The following parts are used only on engines equipped with Delco-Remy starters.

1	16.61-00040	1	Starting Motor RH Rot
1	16.61-00041	1	Starting Motor LH Rot
2	16.61-00037	1	Solenoid Delco
3	16.11-00346	1	Bolt—Inboard
4	16.11-00347	1	Bolt—Outboard
5	16.70-08431	1	Support Bracket
6	16.36-00000	1	Hex Nut ¼"—20 Attaches bracket to starting motor stud
7	16.42-00001	1	Lockwasher ¼"
8	16.30-00058	1	Capscrew ⅝"—18 x ½" Bracket to cylinder block
9	16.42-00002	1	Lockwasher ⅝"

NOTE: Delco-Remy and Prestolite starters have been used on these engines. Use replacement units of the same make.

SHUNT, TERMINAL BLOCK & FASTENINGS

10	16.61-00036	1	Relay
11	16.35-00028	2	Self Tapping Screw—Attaches relay to 16.70-08393 bracket
12	16.70-08393	1	Bracket—Shunt and Voltage Regulator and Starter Relay
13	16.30-00120	2	Capscrew ⅜"—16 x ¼" Bracket to cylinder block
14	16.42-00004	2	Lockwasher ⅜"
15	16.69-00087	1	Shunt
16	16.35-00025	2	Self Tapping Screw—Shunt to bracket
16	16.41-00003	2	Washer 1⅜"
	16.12-00285	1	Clip—Attach to shunt (Motorola only)
17	16.70-08396	1	Terminal Block Bracket—Attaches by screws used to bolt pressure valve housing to left riser
18	16.69-00078	1	Terminal Block Assembly
19	16.35-00027	4	Self Tapping Screw #10 x ¾"—Terminal block to bracket

Code No.	Part No.	No. Req'd	Name
<u>WIRING</u>			
	16.63-08109	1	Wire Assembly—Starting Motor to Terminal Block used with PRESTOLITE Starting Motor ONLY
	16.63-08399	1	Wire Assembly—Starting Motor to Shunt
	16.63-07860	1	Wire Assembly—Alternator to Shunt
	16.63-07862	1	Wire Assembly—Shunt to Terminal Block
	16.63-08405	1	Wire Assembly—Coil (+) to Terminal Block
			NOTE: The following four parts are used only on engines equipped with Delco starters.
	16.63-08398	1	Wire Assembly—Relay #1 to Starter
	16.63-07933	1	Wire Assembly—Relay#2 to Starter
	16.63-07936	1	Wire Assembly—Relay #3 to Ground
	16.63-07672	1	Wire Assembly—Relay #4 to Terminal Block
	16.12-00285	2	Wire Clip—Attach to inside of the LH Valve Cover to Retain the Coil (+) to Terminal Block Wire Assembly.
	16.63-00034	1	Wire Harness Assembly—After Engine 307Q-103961, After Engine 307QL-151034

Chris-Craft®

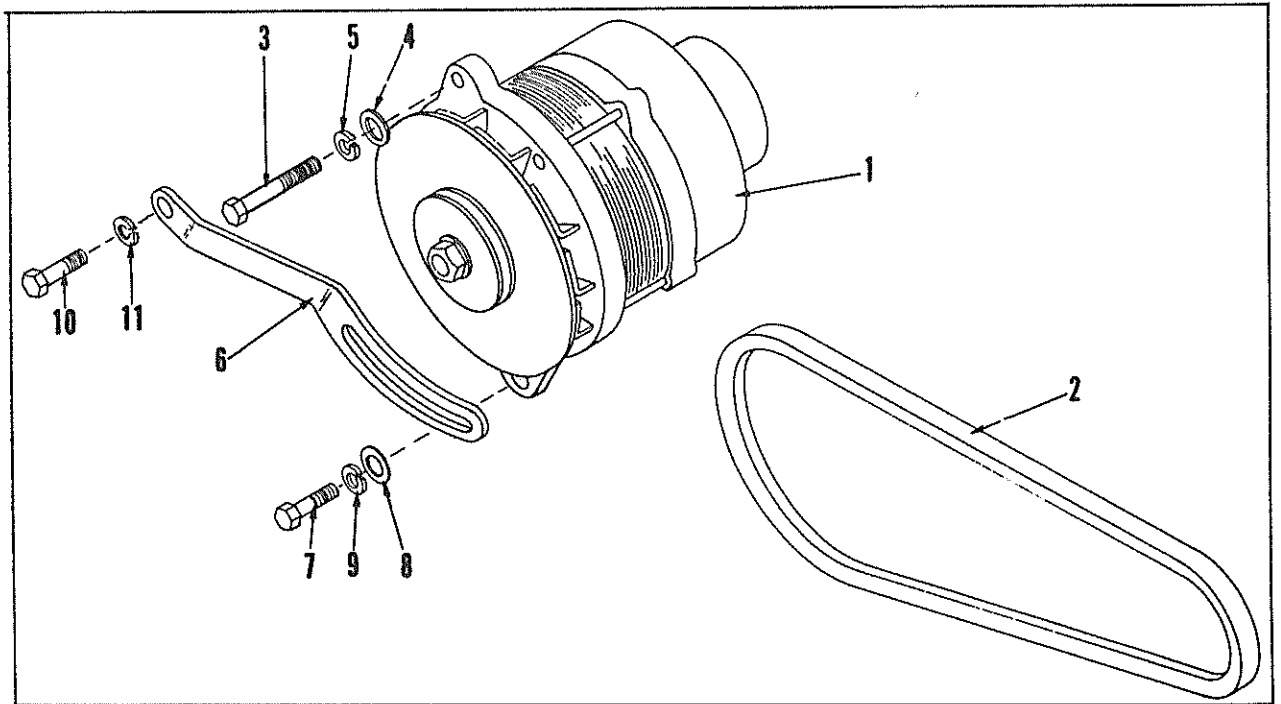

Chris-Craft

Code No.	Part No.	No. Req'd	Name
----------	----------	-----------	------

ALTERNATOR & VOLTAGE REGULATOR

NOTE: Motorola and Prestolite electrical systems have been used on these engines. Since the alternator and voltage regulator must be matched to operate properly, use replacement units of the same make.

The following parts are used only on engines equipped with Motorola.

1	16.65-00033	1	Alternator Assembly (Includes parts designated by a (+) sign)
	16.65-00015	1	+Alternator Assembly Only
	16.65-00034	1	+Fan
	16.65-00018	1	+Woodruff Key
	16.65-00019	1	+Pulley
2	16.97-08370	1	Alternator Belt
	16.65-00020	1	+Lockwasher $\frac{5}{8}$ "
	16.65-00021	1	+Nut $\frac{5}{8}$ "—18
	16.65-00022	1	+Cable Assembly—Alternator to Voltage Regulator
	16.60-00030	1	Voltage Regulator
	16.35-00031	3	Self Tapping Screw—Type S #10 x $\frac{1}{2}$ "
	16.43-00009	3	Toothlock Washer—Type A #10
	16.63-08167	1	Wire Assembly—Voltage Regulator to Coil

The following parts are used only on engines equipped with Pestolite.

1	16.65-00026	1	Alternator Assembly (Includes parts designated by a (+) sign)
	16.65-00027	1	+Alternator Assembly Only
	16.65-00028	1	+Spacer
	16.65-00029	1	+Fan
	16.65-00030	1	+Pulley
2	16.97-08370	1	Alternator Belt
	16.65-00009	1	+Woodruff Key
	16.65-00031	1	+Spacer Washer
	16.65-00010	1	+Washer
	16.65-00011	1	+Nut
	16.60-00031	1	Voltage Regulator
	16.35-00031	2	Self Tapping Screw Type S #10 x $\frac{1}{2}$ "
	16.43-00009	2	Toothlock Washer Type A #10
	16.41-00001	2	Washer $\frac{3}{16}$ "

The following parts are common to both Motorola and Prestolite equipped engines.

NOTE: The following three parts attach the alternator to left header.

3	16.30-00140	1	Capscrew $\frac{3}{8}$ "—16 x 2"
4	16.41-00020	1	Washer $1\frac{1}{2}$ "
5	16.42-00004	1	Lockwasher $\frac{3}{8}$ "
6	16.70-08369	1	Alternator Adjusting Bracket
7	16.30-00066	1	Capscrew $\frac{5}{16}$ "—18 x 1" Bracket to Alternator
8	16.41-00024	1	Washer $1\frac{1}{2}$ "
9	16.42-00002	1	Lockwasher $\frac{5}{16}$ "
10	16.30-00152	1	Capscrew $\frac{3}{8}$ "—16 x $2\frac{3}{4}$ "—Adjusting Bracket to Flywheel Cover
11	16.42-00004	1	Lockwasher $\frac{3}{8}$ "

*Chris * Craft*

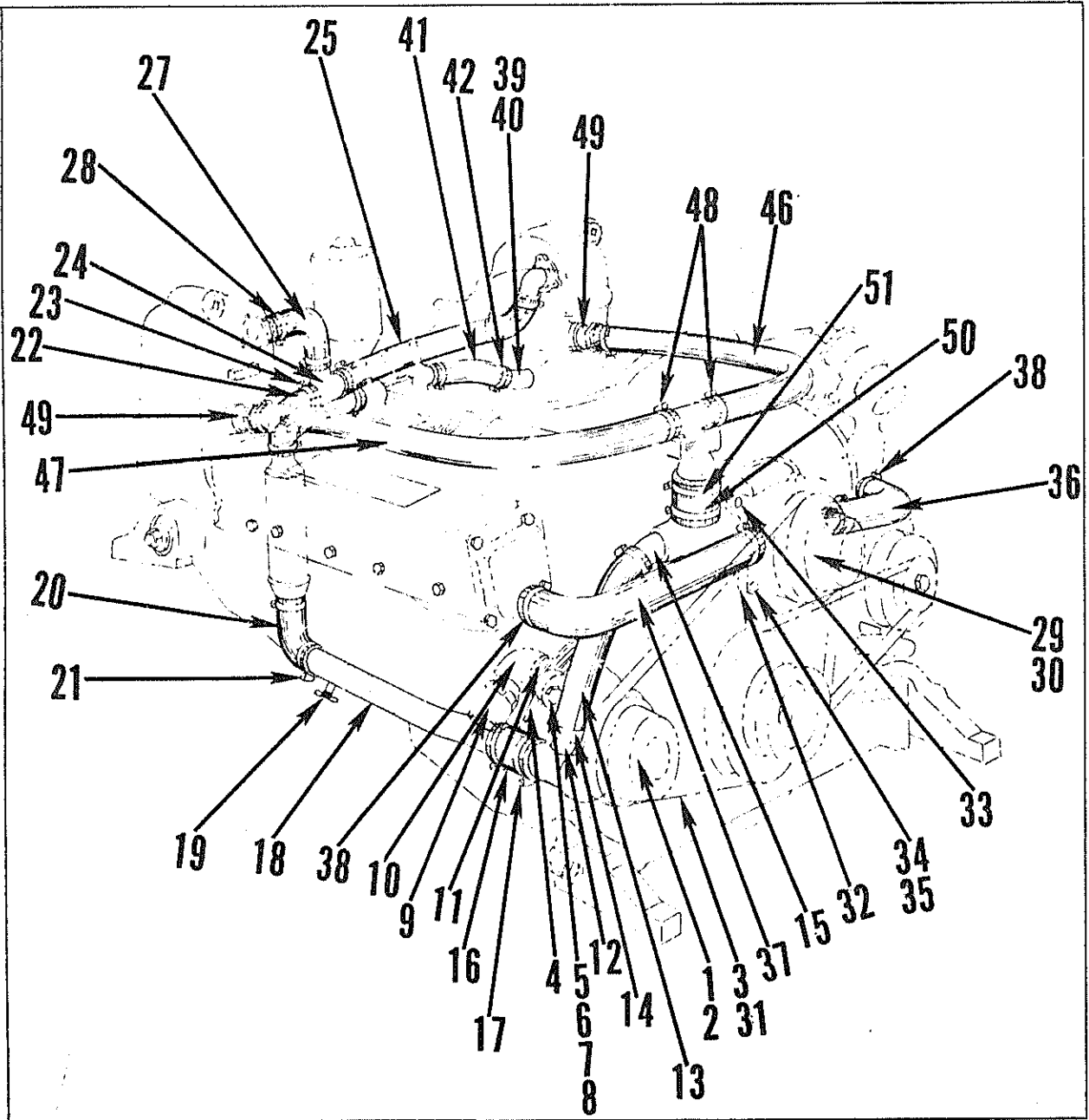

*Chris*Craft*

Code No.	Part No.	No. Req'd	Name
SEA WATER PUMP SYSTEM			
1	16.95-08371	1	Sea Water Pump and Pulley Assembly (Consisting of the following two parts): NOTE: When replacing the sea water pump pulley before engine serial numbers 307Q (102067), 327Q (210370), the pin must be removed.
2	16.20-08314	1	Sea Water Pump Pulley
	16.96-00088	1	Sea Water Pump Repair Kit (Consists of bushing, bearing, seal and seat, gasket and impellers.)
3	16.97-08377	1	Sea Water and Circulating Pump Belt
	16.30-00132	1	Capscrew $\frac{3}{8}$ "—16 x $1\frac{1}{2}$ "—Pump to Flywheel Cover
	16.42-00004	1	Lockwasher $\frac{3}{8}$ "
4	16.70-08353	1	Adjusting Bracket—Sea Water Pump
	16.30-00120	1	Capscrew $\frac{3}{8}$ "—16 x $\frac{3}{4}$ "—Bracket to Flywheel Cover
	16.42-00004	1	Lockwasher $\frac{3}{8}$ "
5	16.30-00132	1	Capscrew $\frac{3}{8}$ "—16 x $1\frac{1}{2}$ "—Adj. Bracket to Pump
6	16.41-00020	1	Plain Washer $1\frac{1}{32}$ "
7	16.42-00004	1	Lockwasher $\frac{3}{8}$ "
8	16.36-00004	1	Hex Nut $\frac{3}{8}$ "—16
NOTE: The three following parts are used at the sea water pump inlet:			
9	16.58-17592	1	Hose Nipple 1" MPT x $1\frac{1}{4}$ " Hose
10	16.58-10048	1	Elbow 1" FPT
NOTE: The following part is used before engine serial numbers: 307Q-102047 327Q-210202 Except 210204, 210205, 210206, 210208, 210209, 210212, 210219, 210220 and 210221.			
11	16.58-10228	1	Pipe Nipple 1" MPT x 3"
NOTE: The following part is used after engine serial numbers: 307Q-102046 327Q-210201 including 210204, 210205, 210206, 210208, 210209, 210212, 210219, 210220 and 210221			
11	16.58-10216	1	Pipe Nipple 1" MPT x 2"
NOTE: The four following parts are used from the sea water pump to flywheel cover:			
12	16.22-08367	1	Sea Water Pump Outlet Tee
NOTE: The following part is used before engine serial numbers: 307Q-102047 327Q-210202 except 210204, 210205, 210206, 210208, 210209, 210212, 210219, 210220 and 210221			
13	16.54-10063	1	Hose 1" ID—3 Ply X 12" Cut 3 inches off for correct length.
NOTE: The following part is used after engine serial numbers: 307Q-102046 327Q-210201 including 210204, 210205, 210206, 210208, 210209, 210212, 210219, 210220 and 210221			
13	16.54-07338	1	Molded Hose
14	16.55-37158	2	Hose Clamp
15	16.58-10060	1	Elbow 45° $\frac{3}{4}$ " MPT x 1" Hose

*Chris * Craft*®

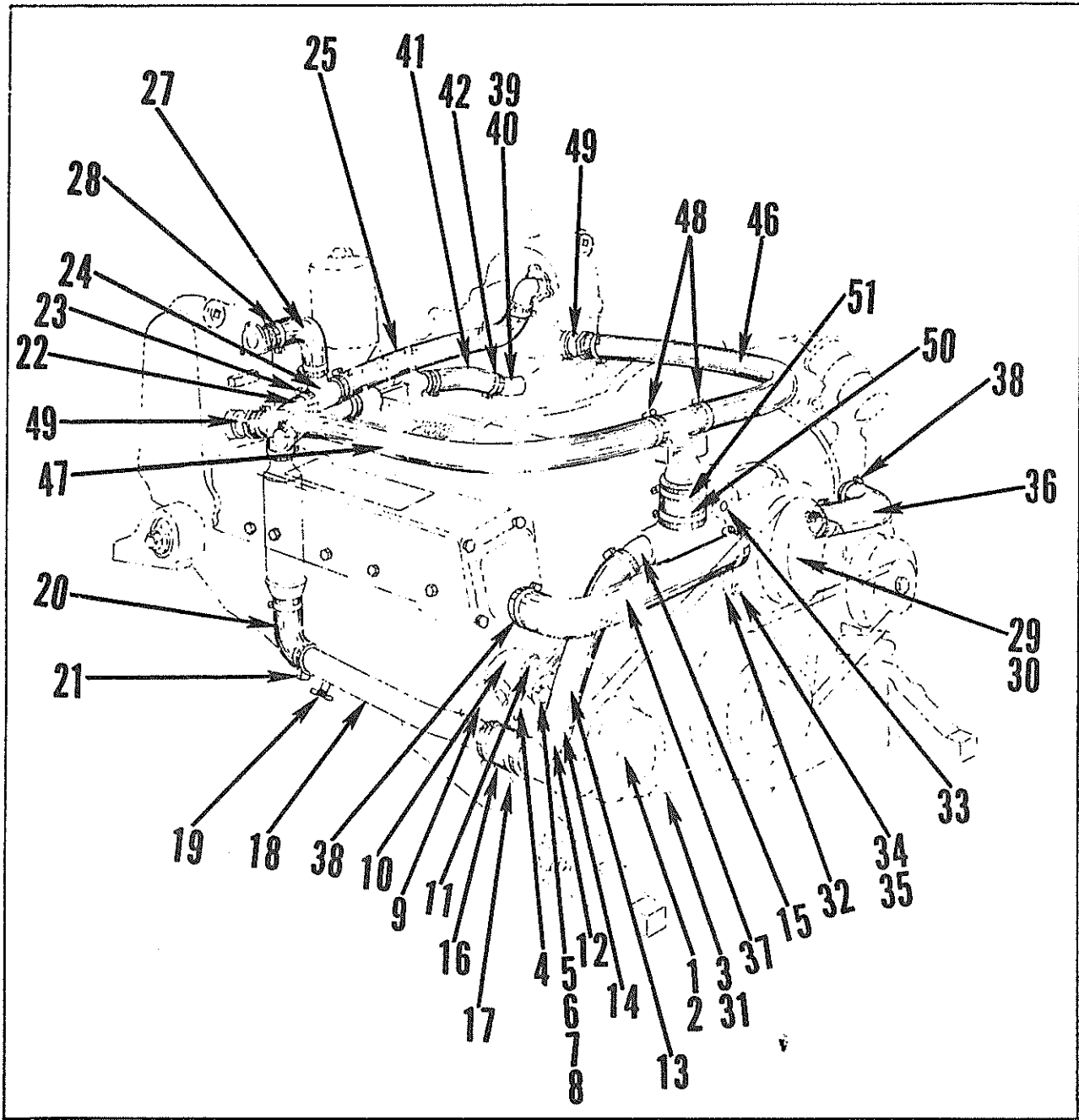

Chris-Craft

Code No.	Part No.	No. Req'd	Name
SEA WATER PUMP SYSTEM			
NOTE: The twelve following parts are used between the sea water pump outlet tee and the reverse gear oil cooler.			
16	16.54-10029	1	Hose 1 1/4"—3 Ply x 3"
17	24.00-00024	2	Hose Clamp
	16.54-08415	1	Molded Hose (V-DRIVE ENGINES ONLY)
18	16.57-58414	1	Line Assembly—Sea Water Pump to Oil Cooler Inlet—Consisting of the following two parts: (WITHOUT V-DRIVE)
	16.57-58413	1	Tube (WITHOUT V-DRIVE)
	16.72-18049	1	Coupling (WITHOUT V-DRIVE)
	16.57-58433	1	Line Assembly—Sea Water Pump to Tee (V-DRIVE ENGINES ONLY)
NOTE: Rework 16.57-58414 Line Assembly by cutting off some of the formed end.			
19	16.58-17981	1	Drain Valve 1/8"—27 NPT
20	16.54-07292	1	Molded Hose
21	24.00-00024	2	Hose Clamp
	24.00-00024	1	Oil Cooler Inlet Tee (V-DRIVE ENGINES ONLY) After 307Q 214834W & 350Q 220312 use 1 16.58-10229 Nipple Barbed Hose 5/8" x 3/4" MPT
	16.55-37304	2	Hose Clamp (V-DRIVE ENGINES ONLY)
NOTE: The five following parts are used between the oil cooler inlet tee and the V-drive housing inlet:			
	16.58-10227	1	Hose Nipple (V-DRIVE ENGINES ONLY)
	16.54-10041	1	Hose 5/8" ID x 23" (V-DRIVE ENGINES ONLY)
	16.55-37158	2	Hose Clamp (V-DRIVE ENGINES ONLY)
	16.58-10059	1	Elbow 5/8" H x 3/8" MPT (V-DRIVE ENGINES ONLY)
	16.58-10226	1	Reducer 1" MPT X 3/8" FPT (V-DRIVE ENGINES ONLY) 6A & 6B Series use 16.58-10229
NOTE: The five following parts are used between the V-drive housing outlet and the left exhaust riser:			
	16.58-10226	1	Reducer 1" MPT X 3/8" FPT (V-DRIVE ENGINES ONLY) 6A & 6B Series use 16.58-10229
	16.58-10059	2	Elbow, 5/8" H x 3/8" MPT (V-DRIVE ENGINES ONLY)
	16.54-10071	1	Hose 5/8" ID x 26" (V-DRIVE ENGINES ONLY)
	16.55-37158	2	Hose Clamp (V-DRIVE ENGINES ONLY)
	16.58-10213	1	Reducer 1/2" MPT x 3/8" FPT (V-DRIVE ENGINES ONLY)
22	16.54-07292	1	Molded Hose—Oil Cooler to Tee
23	24.00-00024	2	Hose Clamp
24	16.22-07574	1	Reducing Tee—To Risers
NOTE: The following two parts are used between tee and left riser:			
25	16.54-07666	1	Molded Hose
26	16.55-37158	2	Hose Clamp
NOTE: The following two parts are used between tee and right riser:			
27	16.54-07338	1	Molded Hose
28	16.55-37158	2	Hose Clamp

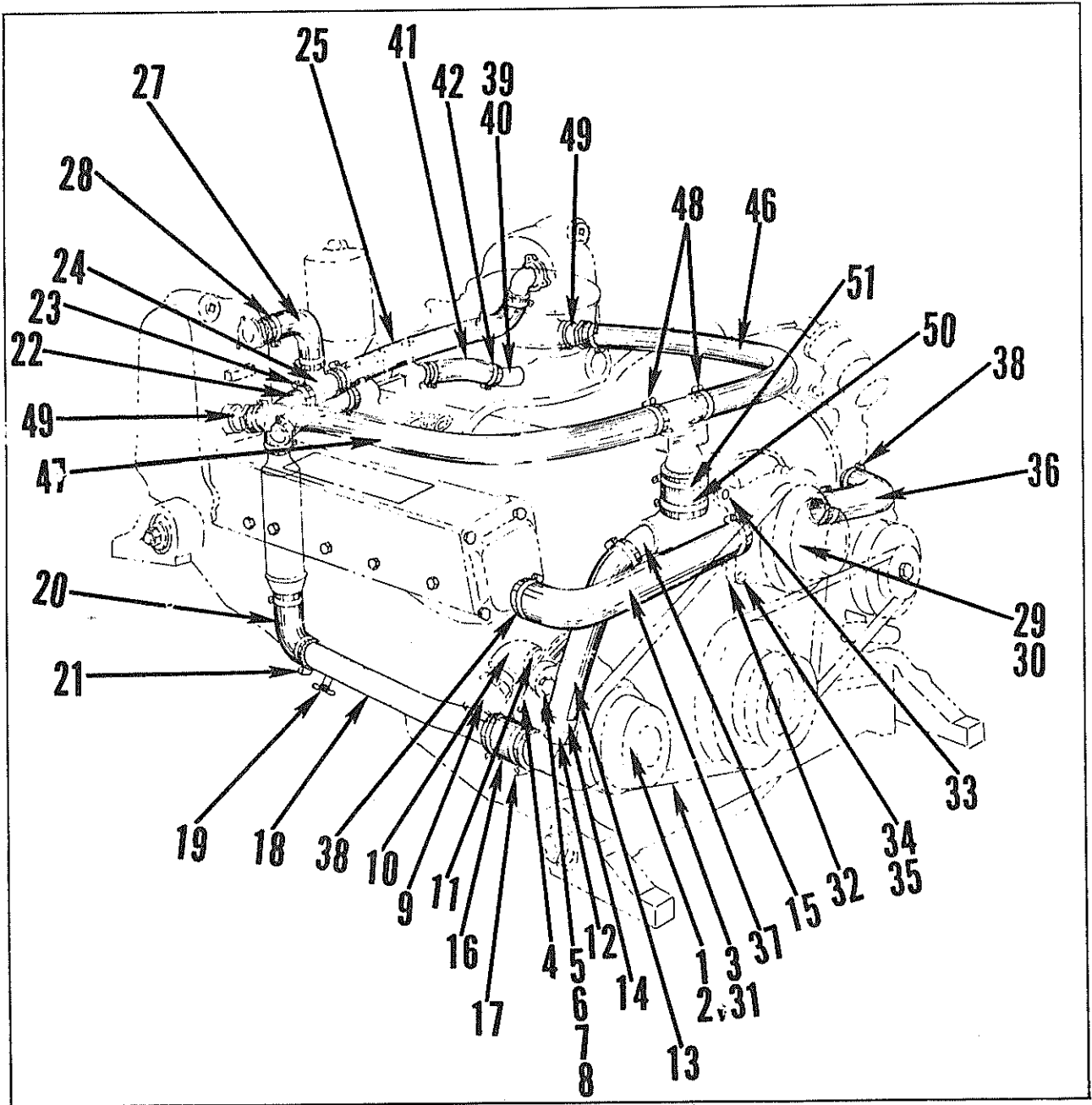

Chris-Craft

Code No.	Part No.	No. Req'd	Name
<u>CIRCULATING WATER PUMP SYSTEM</u>			
29	16.95-08372	1	Circulating Water Pump and Pulley Assembly—RH Rot. ONLY. Consist of the following two parts: NOTE: When replacing the circulating water pump pulley before engine serial numbers 307Q (102067), 327Q (210370), the pin must be removed.
29	16.95-08373	1	Circulating Water Pump and Pulley Assembly—LH Rot. ONLY. Consist of the following two parts:
30	16.20-08314	1	Pulley
31	16.97-08377	1	Circulating and Sea Water Pump Belt
32	16.50-08316	1	Gasket—Circulating Pump to Flywheel Cover
33	16.30-00180	1	Capscrew $\frac{3}{8}$ "—16 x 4 $\frac{1}{2}$ "
34	16.30-00138	2	Capscrew $\frac{3}{8}$ "—16 x 1 $\frac{7}{8}$ "
35	16.30-00144	1	Capscrew $\frac{3}{8}$ "—16 x 2 $\frac{1}{4}$ " (Top outside hole of circulating pump)
35	16.42-00004	4	Lockwasher $\frac{3}{8}$ " NOTE: The following three parts are used from the circulating pump outlets to the exhaust manifold headers.
36	16.54-08385	1	Molded Hose—Pump to Left Header
37	16.54-08384	1	Molded Hose—Pump to Right Header
38	16.55-37304	4	Hose Clamp NOTE: The following four parts are used from the exhaust risers to the cylinder block water inlet fitting cap.
39	16.58-10047	2	Street Elbow, 45° 1" NPT (One in Each Riser)
40	16.58-17288	2	Hose Nipple 1" x 1 $\frac{1}{2}$ "
41	16.54-08415	2	Molded Hose
42	16.55-37304	4	Hose Clamp NOTE: The following four parts are used between the thermostat housing cap and the exhaust risers.
46	16.54-08497	1	Water Hose, Molded—Thermostat Housing to Left Riser
47	16.54-08498	1	Water Hose, Molded—Thermostat Housing to Right Riser
48	16.55-37158	4	Hose Clamp
49	16.58-17120	2	Elbow, 45° $\frac{3}{4}$ " MPT x 1" Hose—One in Each Riser NOTE: The two (2) following parts connect the thermostat housing with the flywheel housing:
50	16.54-10073	1	Water Hose 1 $\frac{3}{4}$ " ID x 2"
51	16.55-37306	2	Hose Clamp
	16.51-00015	1	"O" Ring—Cover Backing Plate

*Chris*Craft*

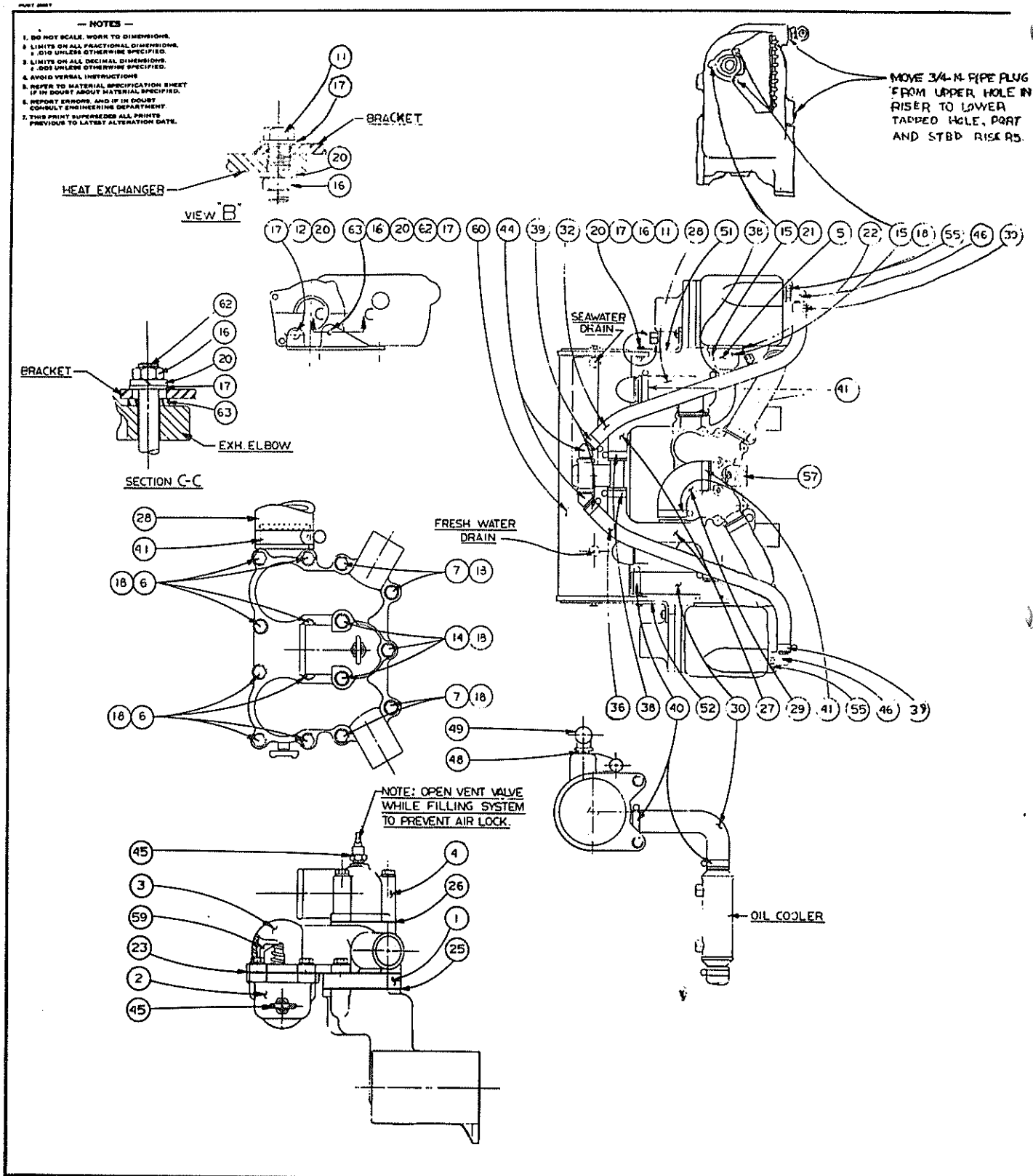

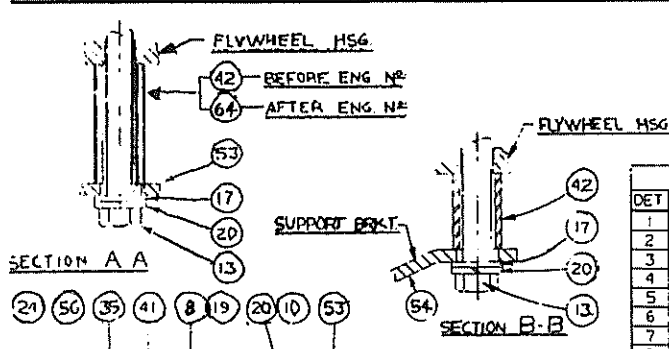

LETTER	BY	ALTERNATIONS	CHKD	DATE
A	WJ	ADD 10 WAS 6		8-27-68
B	WJ	ADD 10 WAS 6		8-16-68
C	WJ	ADD 10 WAS 6		8-16-68
D	WJ	ADD 10 WAS 6		8-16-68
E	WJ	ADD 10 WAS 6		8-16-68
F	WJ	ADD 10 WAS 6		8-16-68
G	WJ	ADD 10 WAS 6		8-16-68
H	WJ	ADD 10 WAS 6		8-16-68
I	WJ	ADD 10 WAS 6		8-16-68
J	WJ	ADD 10 WAS 6		8-16-68
K	WJ	ADD 10 WAS 6		8-16-68
L	WJ	ADD 10 WAS 6		8-16-68
M	WJ	ADD 10 WAS 6		8-16-68
N	WJ	ADD 10 WAS 6		8-16-68
O	WJ	ADD 10 WAS 6		8-16-68
P	WJ	ADD 10 WAS 6		8-16-68
Q	WJ	ADD 10 WAS 6		8-16-68
R	WJ	ADD 10 WAS 6		8-16-68
S	WJ	ADD 10 WAS 6		8-16-68
T	WJ	ADD 10 WAS 6		8-16-68
U	WJ	ADD 10 WAS 6		8-16-68
V	WJ	ADD 10 WAS 6		8-16-68
W	WJ	ADD 10 WAS 6		8-16-68
X	WJ	ADD 10 WAS 6		8-16-68
Y	WJ	ADD 10 WAS 6		8-16-68
Z	WJ	ADD 10 WAS 6		8-16-68

DET	PART NO	NAME OR DESCRIPTION	QTY
1	06.20-3539	PLATE-ORIFICE	1
2	06.20-0831J	HOUSING-THERMOSTAT	1
3	06.20-0831I	CAP-THERMOSTAT	1
4	06.20-08335	ELBOW-CYL. PLK. WATER INLET	1
5	06.22-07532	HOUSING-PRLSSS:RE. VALVE	1
6	06.30-03316	SCREW-HEX. HD. 1/4-20 X 7/8	8
7	06.30-03312	SCREW-HEX. HD. 1/4-20 X 1-1/4	4
8	06.30-03366	SCREW-HEX. HD. 5/16-18 X 1	1
9	06.30-00068	SCREW-HEX. HD. 5/16-18 X 1-1/8	1
10	06.30-00120	SCREW-HEX. HD. 3/8-16 X 3/4	1
11	06.30-00127	SCREW-HEX. HD. 3/8-24 X 1-1/8	4
12	06.30-00140	SCREW-HEX. HD. 3/8-16 X 2	2
13	06.30-00172	SCREW-HEX. HD. 3/8-16 X 4	2
14	06.30-00573	SCREW-HEX. HD. 1/4-20 X 4-1/2	3
15	06.30-40001	SCREW-MACH. FL. HD. 1/4-20 X 7/8	3
16	06.36-30000	NUT-HEX. 3/8 X 24	6
17	06.41-00006	WASHER-PLAIN, 25/64 X 11/16 X 1/16	10
18	06.42-00001	WASHER-LOCK, 1/4	17
19	06.42-00002	WASHER-LOCK, 5/16	2
20	06.42-00004	WASHER-LOCK, 3/8	12
21	06.50-00073	GASKET-COPPER ASBESTOS	1
22	06.50-07290	GASKET-PRESSURE REL. VALVE HSG.	1
23	06.50-08312	GASKET-THERMOSTAT HOUSING	1
24	06.50-08317	GASKET-INTAKE MANIFOLD WATER OUTLET	1
25	06.50-08319	GASKET-ORIFICE PLATE TO CYL. BLK. INLET	1
26	06.50-08339	GASKET-CYL. BLK. WATER INLET ELBOW	1
27	06.54-08388	HOSE-MOLDED	2
28	06.54-08389	HOSE-MOLDED	1
29	06.54-07576	HOSE-MOLDED	1
30	06.54-08448	HOSE-MOLDED, OIL COOLER TO HEAT EXCHANGER	1
31	06.54-10035	HOSE-1/4 I.D. X 5	1
32	06.54-10041	HOSE-5/8 I.D. X 23	1
33	06.54-10079	HOSE-5/8 I.D. X 3	1
34	06.54-10066	HOSE-5/8 I.D. X 18	1
35	06.54-10073	HOSE-1-3/4 I.D. X 2	1
36	06.54-10078	HOSE-5/8 I.D. X 20	1
37	06.55-37122	CLAMP-HOSE	1
38	06.55-37124	CLAMP-HOSE	4
39	06.55-37158	CLAMP-HOSE	6
40	06.55-37304	CLAMP-HOSE	4
41	06.55-37306	CLAMP-HOSE	6
42	06.57-07667	SPACER-.459 I.D. X 5/8 O.D. X 1	2
43	06.58-17729	NIPPLE-HOSE, 1 X 2-1/2	1
44	06.58-17972	ELBOW-45°, 5/8 HOSE X 1/2 NPT.	2
45	06.58-17981	VALVE-DRAIN, 1/8	2
46	06.58-10059	ELBOW-90°, 5/8 HOSE X 3/8 MPT.	2
47	06.58-10229	NIPPLE-HOSE, 5/8 HOSE X 3/4 MPT.	1
48	06.58-10085	NIPPLE-PIPE, 1/2 X CLOSE	1
49	06.58-10194	TEE-PIPE, 1/2 X 1/2 X 1/2	1
50	06.70-00005	CAP-ASSY, FILLER 7 PSI	1
51	06.70-08337	BRACKET-HEAT EXCHANGER L.H.	1
52	06.70-08338	BRACKET-HEAT EXCHANGER R.H.	1
53	06.70-08386	SUPPORT-EXPANSION TANK L.H.	1
54	06.70-08387	SUPPORT-EXPANSION TANK R.H.	1
55	06.72-17737	NOZZLE-EXHAUST RISER	2
56	06.92-07772	DECAL-FRESH WATER COOLING SYSTEM	1
57	06.92-08442	TAG-F.W. COOLING SYSTEM FILLING INST.	1
58	06.99-00049	INHIBITOR-RUST	2
59	06.99-08329	THERMOSTAT	2
60	06.99-08336	EXCHANGER-ASSY, HEAT	1
61	06.99-08379	TANK ASSY-EXPANSION	1
62	06.44-38383	STUD 3/8 X 9-1/2	2
63	06.41-10006	WASHER PLAIN 25/64 X 3/4 X 1/8	2
64	06.57-08503	SPACER-.459 I.D. X 5/8 O.D. X 1.57	1

- GENERAL INSTALLATION NOTES:
1. WATER CIRCULATING SYSTEM CAPACITY 2.3 QUARTS
 2. ADD DETAIL #58 RUST INHIBITOR TO THE CIRCULATING SYSTEM.
 3. ALWAYS USE A SUITABLE SCREEN OR STRAINER BETWEEN THE SEAWATER INLET AND THE SEAWATER PUMP
 4. USE EXISTING COOLING SYSTEM PARTS FROM STANDARD ENGINE EXCEPT AS SHOWN.
 5. THERMOSTAT TEMPERATURE RANGE 140° TO 165° F.

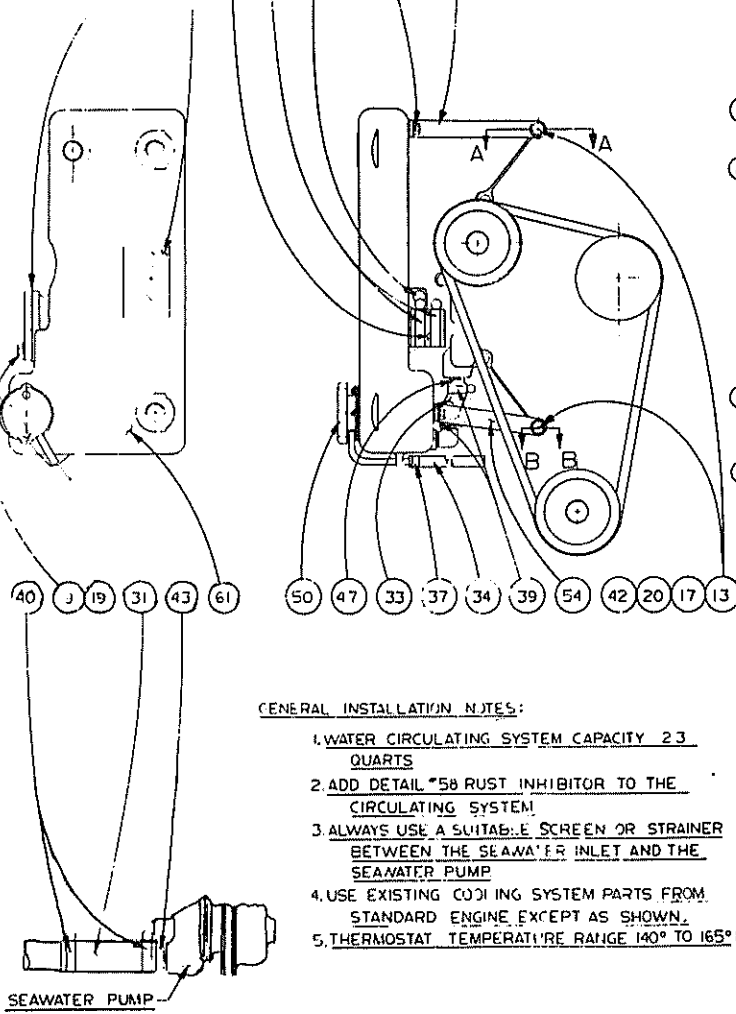

©-FOR SERVICE ONLY 55.00-00112

MODEL 307Q-327Q

06.96-08450

CHRIS-CRAFT CORPORATION				MARINE ENGINE DIVISION ALBION, MICHIGAN			
BY	DESIGNED	CHECKED	DATE	MATERIAL SPECIFICATION	NAME OR DESCRIPTION	PART NUMBER	
			5-11-68		KIT CLOSED COOLING SYSTEM	8450	

N.D.O. 5038



Code No.	Part No.	No. Req'd	Name
----------	----------	-----------	------

REVERSE GEAR - HYDRAULIC - PARAGON P-300**COMPLETE ASSEMBLY**

06.01-00016	1	Reverse Gear Assembly—RH Rot. Direct (P-31R)
06.01-00017	1	Reverse Gear Assembly—LH Rot. Direct (P-31L)
06.03-10018	1	Rev. and Red. Gear Assy—RH Rot. 1.5:1 (P-32AR)
06.03-10019	1	Rev. and Red. Gear Assy—LH Rot. 1.5:1 (P-32AL)
16.03-20012	1	Rev. and Red. Gear Assy—RH Rot. 2.0:1 (P-33AR) 307Q only
16.03-20013	1	Rev. and Red. Gear Assy—LH Rot. 2.0:1 (P-33AL) 307Q only
06.03-20022	1	Rev. and Red. Gear Assy—RH Rot. 2.0:1 (P-33R) 327Q only
06.03-20023	1	Rev. and Red. Gear Assy—LH Rot. 2.0:1 (P-33L) 327QL only
06.03-30020	1	Rev. and Red. Gear Assy—RH Rot. 2.5:1 (P-34BR)
06.03-30021	1	Rev. and Red. Gear Assy—LH Rot. 2.5:1 (P-34BL)
06.03-40014	1	Rev. and Red. Gear Assy—RH Rot. 3.0:1 (P-35BR)
06.03-40015	1	Rev. and Red. Gear Assy—LH Rot. 3.0:1 (P-35BL)

Interchangeability not affected.

REVERSE GEAR - HYDRAULIC - PARAGON PV-300**COMPLETE ASSEMBLY (V-DRIVES)**

06.05-00008	1	V-Drive Assembly—RH Rot. Direct (PV-3125R)
06.05-00009	1	V-Drive Assembly—LH Rot. Direct (PV-3125L)
06.05-10008	1	V-Drive Assembly—RH Rot. 1.5:1 (PV-3225R)
06.05-10009	1	V-Drive Assembly—LH Rot. 1.5:1 (PV-3225L)
06.05-20008	1	V-Drive Assembly—RH Rot. 2.0:1 (PV-3325R)
06.05-20009	1	V-Drive Assembly—LH Rot. 2.0:1 (PV-3325L)
06.05-30008	1	V-Drive Assembly—RH Rot. 2.5:1 (PV-3425R)
06.05-30009	1	V-Drive Assembly—LH Rot. 2.5:1 (PV-3425L)

(New Style Engine Mounts Required on Older Engines)

Interchangeable with New Style Engine Mount.

SHAFT HALF COUPLINGS

16.20-00054	1	Shaft Coupling—1" bore, 4" face dia., 2 $\frac{5}{8}$ " Pilot dia.
16.20-00055	1	Shaft Coupling—1 $\frac{1}{4}$ " bore, 4" face dia., 2 $\frac{5}{8}$ " Pilot diameter
16.20-00056	1	Shaft Coupling—1 $\frac{3}{8}$ " bore, 4" face dia., 2 $\frac{5}{8}$ " Pilot diameter
16.20-00057	1	Shaft Coupling—1 $\frac{1}{2}$ " bore, 4" face dia., 2 $\frac{5}{8}$ " Pilot diameter
16.30-00125	4	Capscrew $\frac{3}{8}$ "—24 x 1"
16.42-00004	4	Lockwasher $\frac{3}{8}$ "
16.31-00002	2	Set Screw $\frac{7}{16}$ "—14 x 1"

GASKET SETS**NOTE:** Gasket sets include all gaskets, seals and "O" rings.

16.50-90091	1	Gasket Set—P31 (Direct Drive)
16.50-90093	1	Gasket Set—P32A, P33A, P34B, P35B (All Reductions)
	1	Gasket Set—PV31 (Direct Drive)
	1	Gasket Set—PV32, 33, 34 (Reductions)

Chris-Craft

Code No.	Part No.	No. Req'd	Name
----------	----------	-----------	------

REVERSE GEAR SECTION

	16.50-07366	1	Gasket—Reverse Gear Housing to Timing Chain Cover
	16.44-07378	2	Stud
	16.43-00002	2	Toothlock Washer $\frac{7}{16}$ "
	16.30-00541	4	Capscrew 12 pt. Head $\frac{7}{16}$ "—14 x $1\frac{1}{2}$ "
	16.42-00006	4	Lockwasher $\frac{7}{16}$ "
	16.58-10077	1	Pipe Nipple $\frac{3}{8}$ " Close
	16.58-10022	1	Coupling

REVERSE GEAR OIL COOLER

1	16.99-08100	1	Oil Cooler
2	16.70-08417	1	Oil Cooler Bracket—Attaches to Cylinder Block Water Inlet Fitting Fastenings—RH Side
3	16.30-00064	2	Capscrew $\frac{5}{16}$ "—18 x $\frac{7}{8}$ "—Cooler to Bracket
4	16.42-00002	2	Lockwasher $\frac{5}{16}$ "
5	16.36-00002	2	Hex Nut $\frac{5}{16}$ "—18
6	16.59-10580	3	Elbow $\frac{1}{2}$ " T x $\frac{3}{8}$ " MPT
7	16.59-10117	1	Connector $\frac{1}{2}$ " T x $\frac{3}{8}$ " MPT—At Gear Outlet
8	16.57-58412	1	Oil Line—Cooler to Reverse Gear
9	16.57-58411	1	Oil Line—Reverse Gear to Cooler

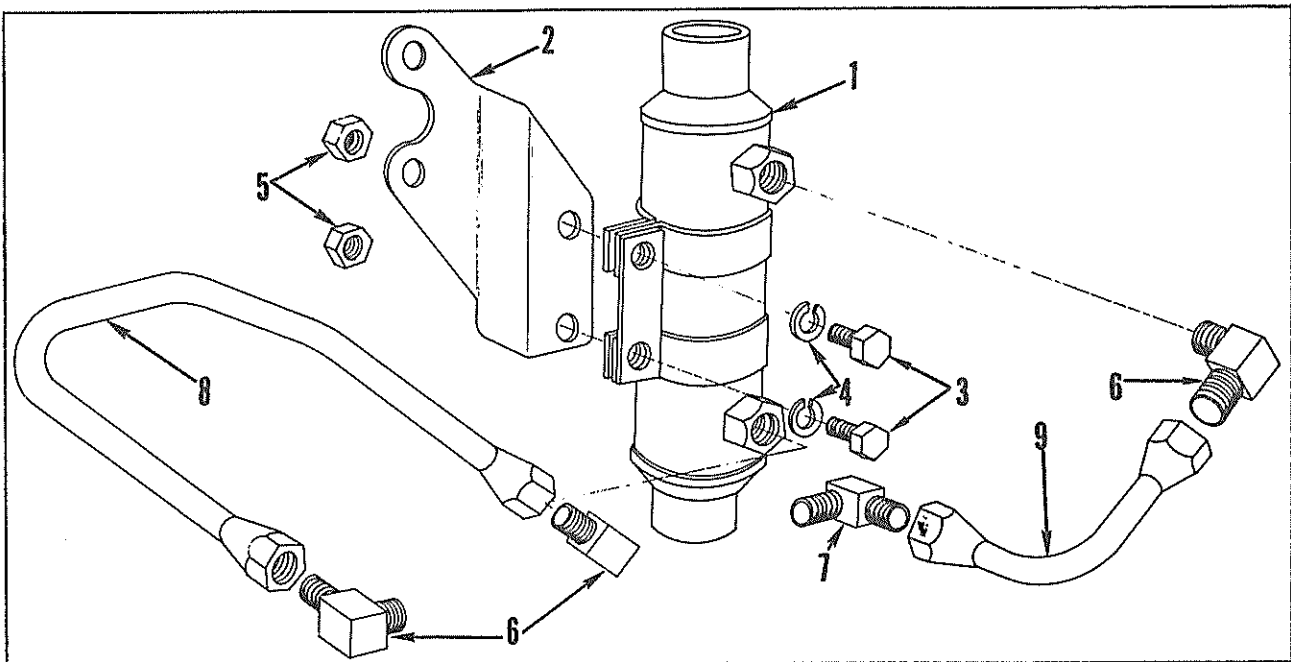

*Chris * Craft*

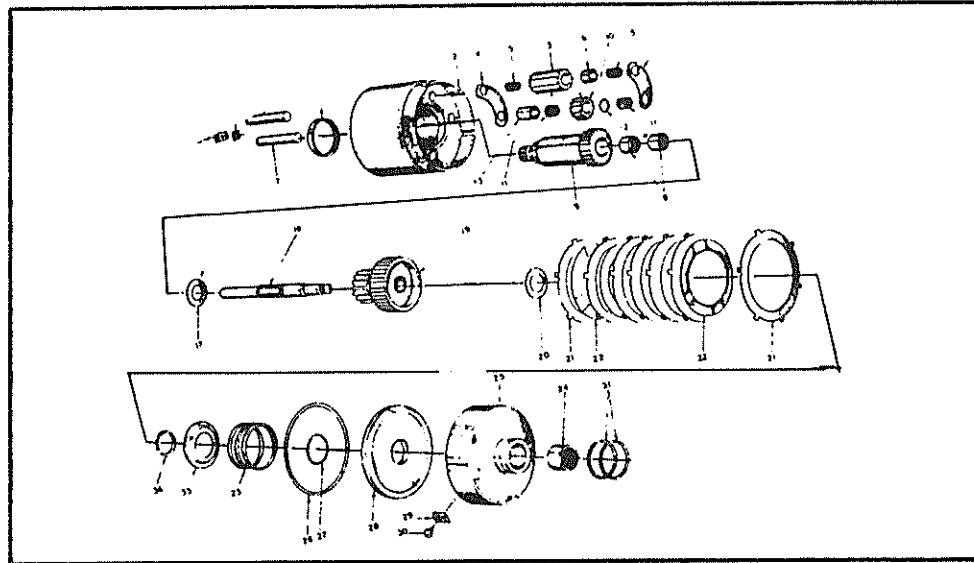

Code No.	Part No.	No. Req'd	Name
<u>REVERSE GEAR - HYDRAULIC - PARAGON P-300</u>			
<u>GEAR CASE ASSEMBLY</u>			
1	16.04-90553	1	Gear Case—Needle Bearing
2	16.04-90554	1	Gear Case
3	16.04-90555	3	Long Pinion
4	16.04-90556	6	Pinion Thrust Pad
5	16.04-90557	6	Roller Bearing
6	16.04-90558	3	Long Pinion Bearing Spacer
7	16.04-90559	6	Pinion Shaft
8	16.04-90560	2	Engine Gear Roller Bearing
9	16.04-90561	1	Engine Gear
10	16.04-90562	3	Short Pinion
11	16.04-90563	6	Roller Bearing
12	16.04-90564	3	Short Pinion Bearing Spacer
13	16.04-90565	3	Short Pinion Spacer
14	16.04-90566	3	Pinion Shaft Locking Tab
15	16.04-90567	3	Case Clip
16	16.04-90568	3	Capscrew— $\frac{5}{16}$ "—18 x $\frac{5}{8}$ "
17	16.04-90569	1	Engine Gear Thrust Washer
<p>NOTE: The following tailshaft used only on the PV-300 reverse gear (without "V" Drive)</p>			
18	16.04-90856	1	Direct Drive Tailshaft
<p>NOTE: The following tailshaft used only on the PV-300 reverse gear (with "V" Drive)</p>			
18	16.04-90912	1	Tailshaft Direct Drive and Reduction
	16.04-90913	1	Tailshaft Retaining Ring—PV-300 Only
	16.04-90943	1	Tailshaft Thrust Washer—PV-300 Only

*Chris * Craft*

Code No.	Part No.	No. Req'd	Name
REVERSE GEAR - HYDRAULIC - PARAGON P-300			
19	16.04-90842	1	Propeller Gear—Direct Drive and Reduction
20	16.04-90744	1	Propeller Gear Thrust Washer—DD and Reduction
21	16.04-90574	7	Steel Clutch Plate
22	16.04-90575	6	Bronze Clutch Plate
23	16.04-90802	1	Screw Collar Spring
24	16.04-90577	1	Screw Collar—Needle Bearing
25	16.04-90800	1	Screw Collar
26	16.51-00006	1	Forward Piston "O" Ring—Outer
27	16.51-00005	1	Forward Piston "O" Ring—Inner
28	16.04-90801	1	Forward Piston
29	16.04-90396	2	Clip—Screw Collar
30	16.04-90395	2	Locking, Capscrew
31	16.04-90397	2	Oil Distributor Seal Rings
NOTE: The following three (3) parts are used only on the P-300 reverse gear (without "V"-drive)			
32	16.04-90580	1	Tailshaft Thrust Washer—Direct Drive Only
33	16.04-90545	1	Tailshaft Seal Washer—Direct Drive Only
34	16.04-90675	1	Woodruff Key #127
35	16.04-90803	1	Spring Retainer
36	16.04-90804	1	Retaining Ring
(Changes from previous P-300 Gear to latest Style— New Style under 6A, 6B Series)			
1A	16.04-91961	1	Case Assembly
6A	16.04-91962	3	Pinion Assembly—Long
9A	16.04-91963	1	Engine Gear Assembly
10A	16.04-91964	3	Pinion Assembly—Short
20A	16.04-91965	1	Propeller Gear Thrust Washer
25A	16.04-91966	1	Screw Collar

*Chris*Craft*

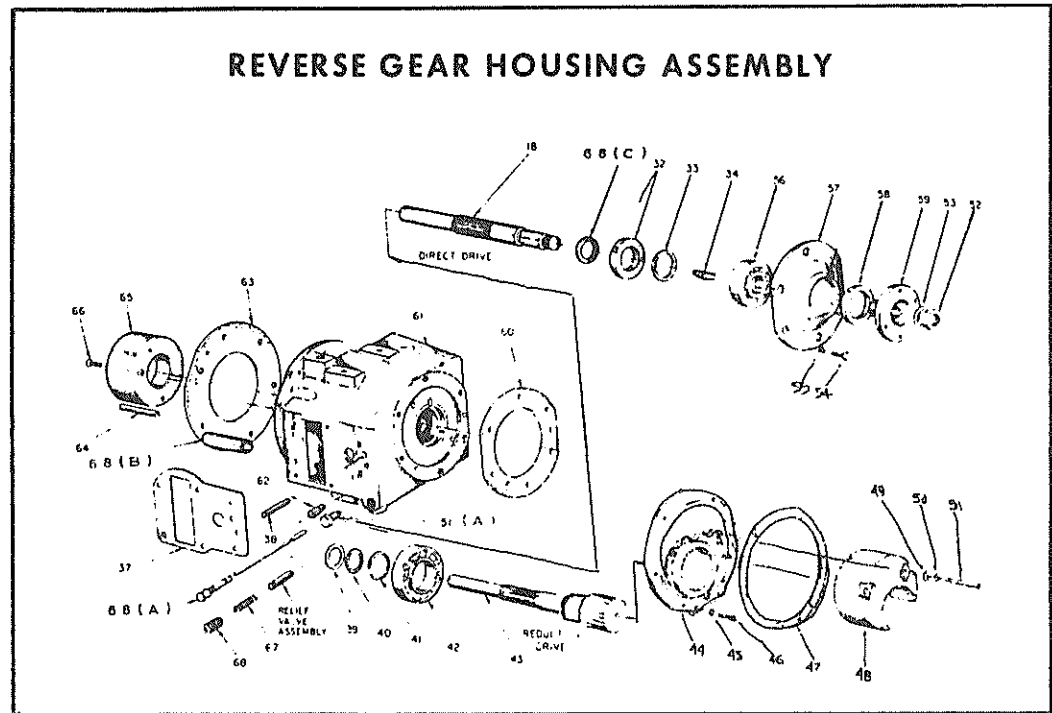

Code No.	Part No.	No. Req'd	Name
REVERSE GEAR - HYDRAULIC - PARAGON P-300			
REVERSE GEAR HOUSING ASSEMBLY			
37A	16.04-91983	1	Cover Gasket
37	16.50-00148	1	Cover Gasket
38	16.04-90807	1	Distributor Tube
39	16.04-90849	1	Tailshaft Needle Thrust Race
40	16.04-90848	1	Tailshaft Needle Thrust Bearing
NOTE: The following part is used on 307Q—1.5:1, 2.0:1 and 327Q—1.5:1.			
41	16.04-90756	1	Retaining Ring
NOTE: The following part is used on 327Q—2.0:1 only.			
41	16.04-90677	1	Retaining Ring
NOTE: The following part is used on 307Q—327Q—2.5:1 and 3.0:1.			
41	16.04-90674	1	Retaining Ring
NOTE: The following part is used on 307Q—1.5:1, 2.0:1 and 327Q—1.5:1.			
42	16.90-00013	1	Ball Bearing
NOTE: The following part is used on 327Q—2.0:1 only.			
42	16.90-00022	1	Ball Bearing
NOTE: The following part is used on 307Q—327Q 2.5:1 and 3.0:1.			
42	16.90-00011	1	Ball Bearing

Code No.	Part No.	No. Req'd	Name
REVERSE GEAR - HYDRAULIC - PARAGON P-300			
REVERSE GEAR HOUSING ASSEMBLY			
43	16.04-90830	1	Tailshaft (307Q—327Q 1.5:1 RH Rot.)
43	16.04-90831	1	Tailshaft (307Q—327Q 1.5:1 LH Rot.)
43	16.04-90832	1	Tailshaft (307Q 2.0:1 RH Rot.)
43	16.04-90833	1	Tailshaft (307Q 2.0:1 LH Rot.)
43	16.04-90944	1	Tailshaft (327Q 2.0:1 RH Rot.)
43	16.04-90945	1	Tailshaft (327Q 2.0:1 LH Rot.)
43	16.04-90834	1	Tailshaft (307Q—327Q 2.5:1 RH Rot.)
43	16.04-90835	1	Tailshaft (307Q—327Q 2.5:1 LH Rot.)
43	16.04-90836	1	Tailshaft (307Q—327Q 3.0:1 RH Rot.)
43	16.04-90837	1	Tailshaft (307Q—327Q 3.0:1 LH Rot.)
44	16.04-90705	1	Adapter Plate (307Q—327Q 1.5:1)
44	16.04-90846	1	Adapter Plate (307Q 2.0:1)
44	16.04-90703	1	Adapter Plate (327Q 2.0:1)
44	16.04-90704	1	Adapter Plate (307Q—327Q 2.5:1)
44	16.04-90847	1	Adapter Plate (307Q—327Q 3.0:1)
45	16.04-90595	2	Adapter Plate Steel—All Reductions
NOTE: Only four (4) of the following parts required on the 327Q 2.0:1.			
46	16.04-90594	6	Capscrew $\frac{3}{8}$ "—16 x $1\frac{1}{4}$ " 1.5:1 and 2.0:1 Red.
46	16.04-90710	4	Capscrew $\frac{3}{8}$ "—16 X $1\frac{1}{2}$ " 2.5:1 and 3.0:1 Red Socket Head
NOTE: The following part is used on 307Q—1.5:1, 2.0:1 and 327Q—1.5:1.			
47	16.50-00072	1	Gasket
NOTE: The following part is used on 307Q—2.5:1, 3.0:1 and 327Q—2.0:1, 2.5:1, 3.0:1.			
47	16.50-00069	1	Gasket
48	16.04-90714	1	Crescent 327Q—2.0:1 ONLY
48	16.04-90715	1	Crescent 307Q—327Q—2.5:1 and 3.0:1 ONLY
NOTE: The following three (3) parts are used on 307Q—2.5:1, 3.0:1 and 327Q—2.0:1, 2.5:1 and 3.0:1.			
49	16.04-90713	2	Plain Steel Washer $1\frac{1}{32}$ " x $1\frac{1}{64}$ " x .065
50	16.04-90712	2	Lockwasher $\frac{3}{8}$ "
51	16.04-90711	2	Capscrew $\frac{3}{8}$ "—16 x $3\frac{1}{2}$ "
51A	16.04-90813	1	Breather

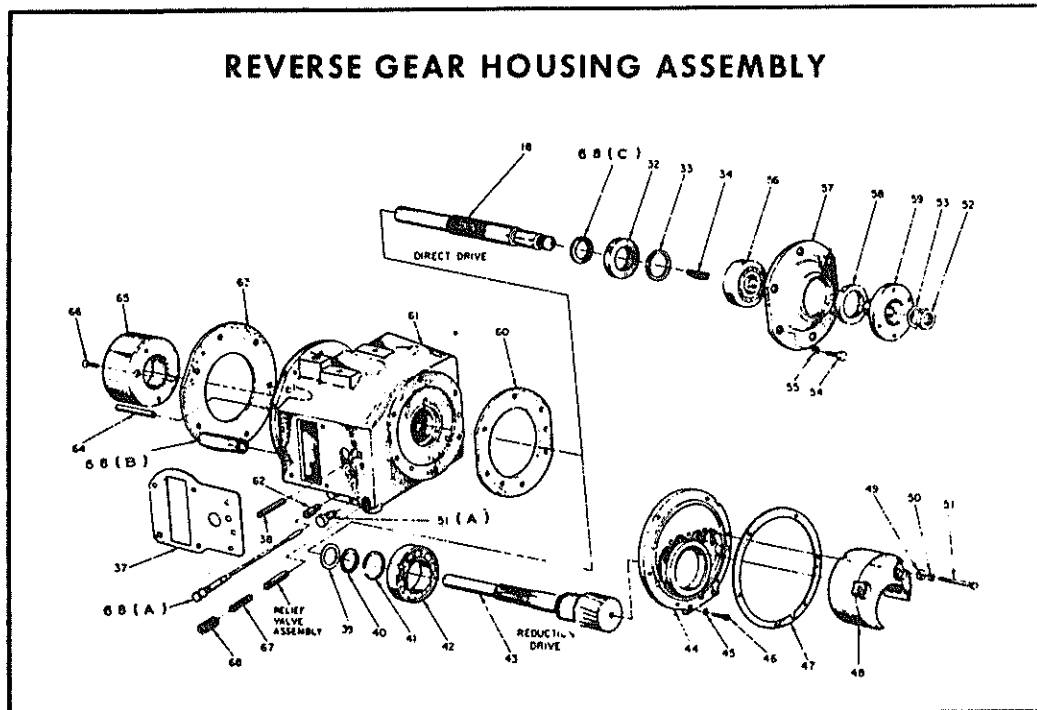

Code No.	Part No.	No. Req'd	Name
----------	----------	-----------	------

REVERSE GEAR - HYDRAULIC - PARAGON P-300
REVERSE GEAR HOUSING ASSEMBLY

52	16.04-90271	1	Locknut—Direct Drive (RDA-363)
53	16.04-90272	1	Lockwasher—Direct Drive Only (RDA-366)
54	16.04-90673	6	Capscrew 3/8"—16 x 7/8"
			NOTE: Before 307Q—102573 and 327Q—213361
55	16.04-90446	6	Lockwasher
56	16.90-00017	1	Ball Bearing
57	16.04-90445	1	Direct Drive Plate
58	16.51-10014	1	Oil Seal
59	16.04-90843	1	Gear Half Coupling—Direct Drive
60	16.50-00036	1	Rear Gasket
61	16.04-90805	1	Housing
61A	16.04-91977	1	Housing—Use on 6A & 6B Series Gear
			NOTE: Before 307Q—102573 & 327Q—213361
62	16.04-90729	1	Dipstick Tube
63	16.50-00086	1	Front Gasket
64	16.04-90810	1	Reverse Band Housing Pin
65	16.04-90584	1	Baffle
66	16.04-90585	2	Flat Head Socket Capscrew 5/16"—18 x 3/4"
67	16.04-90826	1	Hold Down Spring
68	16.04-90825	1	Square Head Pipe Plug 3/4"—14
68A	16.04-90828	1	Dipstick (X-12472) Includes 2-16.04-90793 Seal
68B	16.04-90581	1	Suction Tube
68C	16.04-90573	1	Washer—Direct Drive Only
68D	16.04-91978	1	Dipstick — Use on 6A & 6B Series Gear

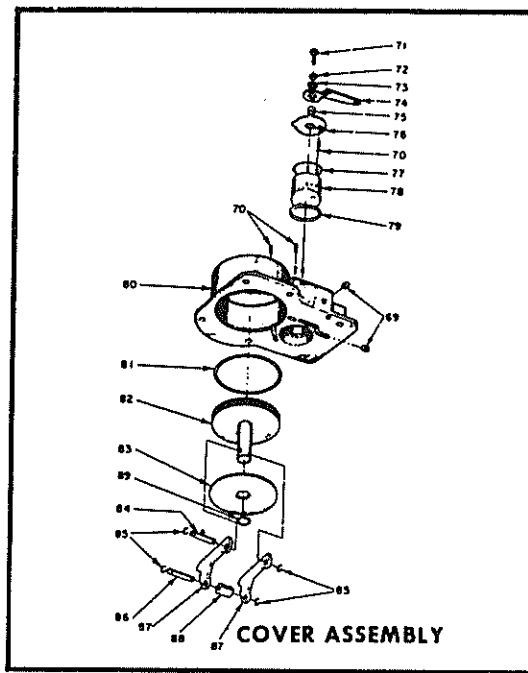

Code No.	Part No.	No. Req'd	Name
REVERSE GEAR - HYDRAULIC - PARAGON P-300			
COVER ASSEMBLY			
69	16.04-90598	3	Pipe Plug 1/8"—27
	16.04-90814	1	Control Valve Assembly (Consist of Code Nos. 70, 71, 72, 74, 75, 77, 78 and 79)
70	16.04-90731	3	Control Lever Pin
71	16.04-90633	1	Capscrew 5/16"—18 X 3/4"
72	16.04-90666	1	Lockwasher 5/16"
73	16.04-90746	1	Plain Washer
74	16.04-90730	1	Control Lever
75	16.04-90733	1	Control Lever Bushing
76	16.04-90732	1	Control Lever Pawl
77	16.51-00007	1	Control Valve "O" Ring
78	16.04-90815	1	Control Valve
79	16.04-90604	1	Control Valve Retaining Ring
80	16.04-90811	1	Cover
	16.04-90816	1	Reverse Piston Assembly (Consist of Code Nos. 81 thru 89)
81	16.51-00011	1	Reverse Piston "O" Ring
82	16.04-90817	1	Reverse Piston and Shaft Assembly
83	16.04-90818	1	Piston Back Up Plate
84	16.04-90820	1	Reverse Piston Shaft Pin
85	16.04-90821	4	Retaining Ring
86	16.04-90820	1	Reverse Band Roll Pin
87	16.04-90819	2	Reverse Band Lever
88	16.04-90822	1	Reverse Band Roll
89	16.51-00012	1	Piston Back Up Plate "O" Ring (Parts used on 6A & 6B Series Reverse Gear only)
80A	16.04-91971	1	Cover
	16.04-91972	1	Control Valve Assembly
78A	16.04-91973	1	Control Valve
83A	16.04-91975	1	Piston Rev.
	16.04-90817		
82A	16.04-91976	1	Shaft—Rev. Piston
	16.04-90817		

*Chris * Craft*

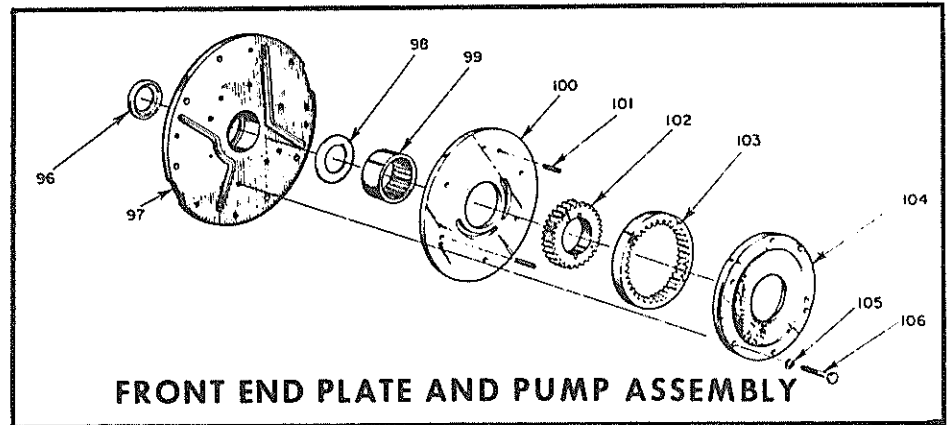
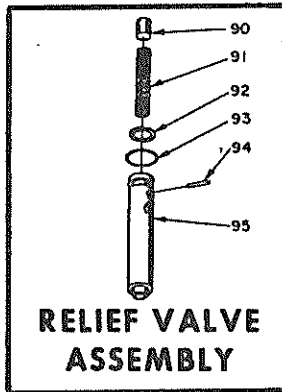

Code No.	Part No.	No. Req'd	Name
REVERSE GEAR - HYDRAULIC - PARAGON P-300			
RELIEF VALVE ASSEMBLY			
90	16.04-90411	1	Relief Valve Plug
91	16.04-90410	1	Relief Valve Spring
92	16.04-90824	1	Relief Valve Retaining Ring
93	16.51-00009	1	Relief Valve "O" Ring
94	16.04-90412	1	Relief Valve Pin
95	16.04-90823	1	Relief Valve Housing
FRONT END PLATE AND PUMP ASSEMBLY			
96	16.51-10013	1	Front Plate Oil Seal
97	16.04-90858	1	Front Plate P-300 Only Before 307Q—102573 & 327Q—213361
97A	16.04-90947	1	Front Plate P-300 Only After 307Q—102572 & 327Q—213360
98	16.04-90622	1	Front Plate Thrust Washer
99	16.04-90623	1	Roller Bearing
100	16.04-90857	1	Pump Port Plate
101	16.04-90624	2	Pump Housing Pin
102	16.04-90626	1	Inner Pump Gear
103	16.04-90439	1	Outer Pump Gear
104	16.04-90625	1	Pump Housing
105	16.04-90644	6	Lockwasher $\frac{5}{16}$ "
106	16.04-90539	6	Capscrew $\frac{5}{16}$ "—18 x 1 $\frac{1}{2}$ "
(To be used on 6A Series Gear only)			
97B	16.04-91967	1	Front Plate Assembly
97B	16.04-91968	1	Front Plate
100A	16.04-91969	1	Pump Assembly
104A		1	Housing Pump

*Chris * Craft*

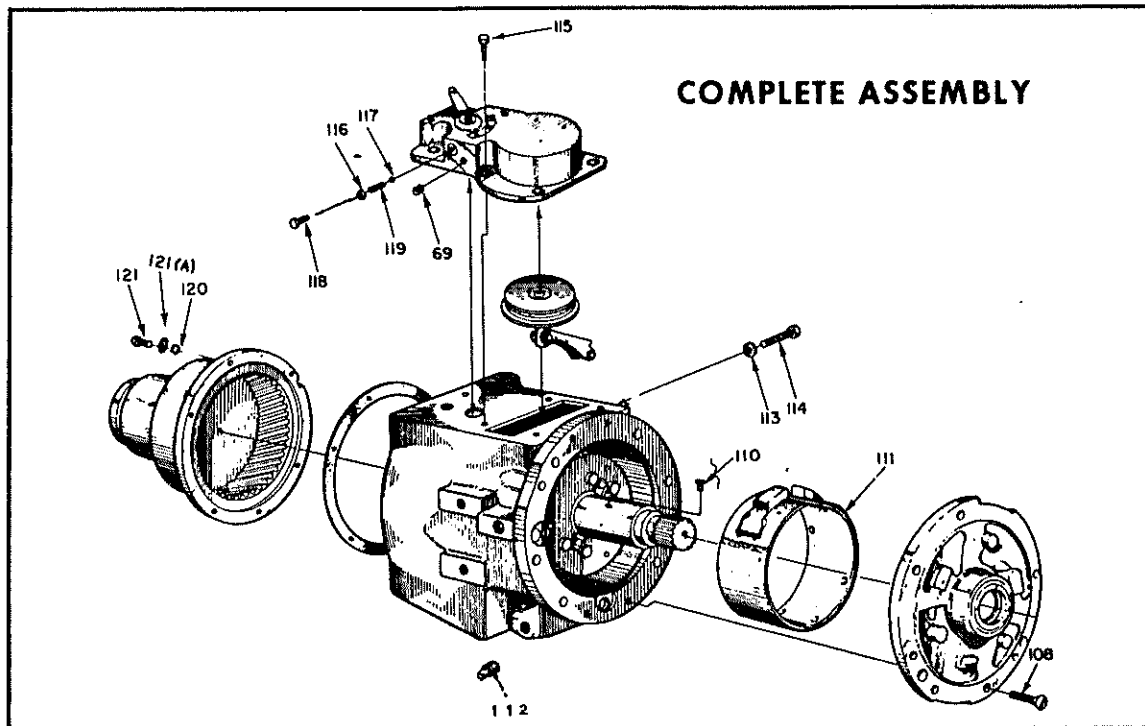

Code No.	Part No.	No. Req'd	Name
REVERSE GEAR - HYDRAULIC - PARAGON P-300			
COMPLETE ASSEMBLY			
108	16.04-90806	6	Flat Head Socket Capscrew Before 307Q—102573 & 327Q—213361
108A	16.04-90720	8	Capscrew, Socket Head $\frac{5}{16}$ "—18 x $\frac{1}{2}$ ", After 307Q—102572 & 327Q—213360
108B	16.04-91982	8	Capscrew—Socket— $\frac{5}{16}$ —18 X $\frac{1}{2}$
110	16.04-90388	1	Pump Key
111	16.04-90808	1	Reverse Band Assembly—Consists of the following three (3) items:
	16.04-90809	1	Band
	16.04-90110	1	Lining
	16.04-90914	1	Lining
	16.04-90662	12	Rivets
112	16.58-80013	1	Pipe Plug
113	16.04-90660	*	Brass Washer $\frac{1}{2}$ "
114	16.04-90878	1	Brake Band Support Screw
115	16.04-90812	6	External Socket Head Capscrew
116	16.04-90467	1	Detent Seal Washer
117	16.04-90606	1	Detent Ball
118	16.04-90667	1	Capscrew $\frac{5}{16}$ "—18 x $\frac{1}{2}$ "
119	16.04-90607	1	Detent Spring
120	16.04-90683	6	Lockwasher $\frac{3}{8}$ "
121	16.04-90682	6	Capscrew $\frac{3}{8}$ "—16 x $1\frac{1}{8}$ "
121A	16.04-90446	2	Seal Washer—2.5:1 Only
*As Required			
118A	16.04-91974	1	Use on 6A Series Gear Detent Plug

Chris-Craft

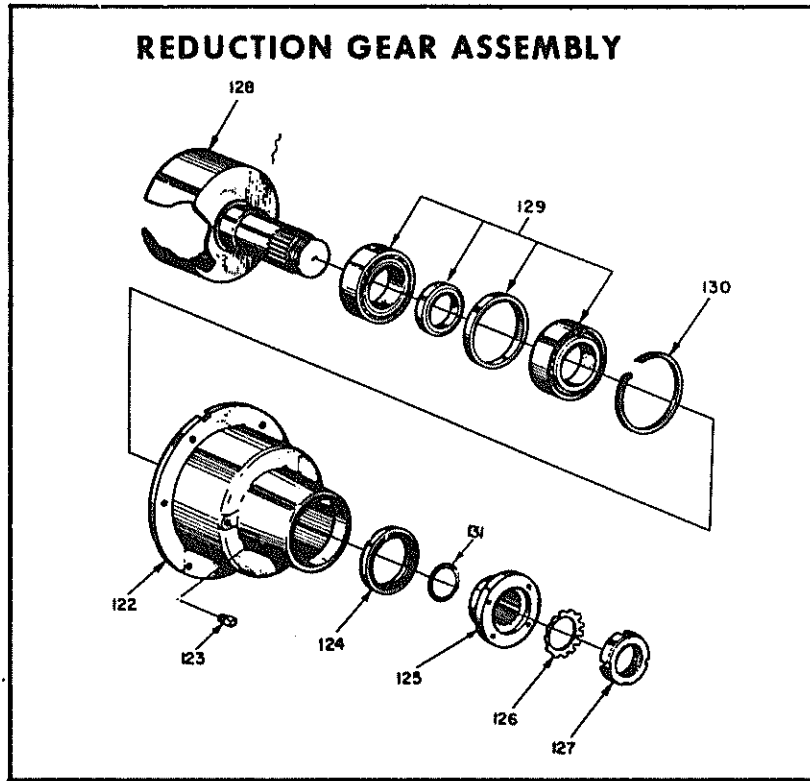

Code No.	Part No.	No. Req'd	Name
<u>REVERSE GEAR - HYDRAULIC - PARAGON P-300</u>			
<u>REDUCTION GEAR ASSEMBLY</u>			
NOTE: The following part is used on 307Q—1.5:1, 2.0:1 and 327Q—1.5:1.			
122	16.04-90844	1	Reduction Gear Housing
NOTE: The following part is used on 307Q—2.5:1, 3.0:1 and 327Q—2.0:1, 2.5:1 and 3.0:1.			
122	16.04-90845	1	Reduction Gear Housing
123	16.58-80010	1	Pipe Plug—Square Head $\frac{3}{8}$ "—18
124	16.51-10020	1	Oil Seal
125	16.04-90853	1	Gear Half Coupling
126	16.04-90854	1	Lockwasher
127	16.04-90855	1	Locknut
NOTE: The following two (2) parts are used on the 307Q—1.5:1, 2.0:1 and 327Q—1.5:1.			
128	16.04-90839	1	Internal Gear (RH Rot. Only)
128	16.04-90838	1	Internal Gear (LH Rot. Only)
NOTE: The following two (2) parts are used on the 307Q—2.5:1, 3.0:1 and 327Q—2.0:1, 2.5:1 and 3.0:1.			
128	16.04-90841	1	Internal Gear (RH Rot. Only)
128	16.04-90840	1	Internal Gear (LH Rot. Only)
NOTE: The following part is used on the 307Q—1.5:1, 2.0:1 and 327Q—1.5:1.			
129	16.04-90850	1	Bearing Assembly
NOTE: The following part is used on the 307Q—2.5:1, 3.0:1 and 327Q—2.0:1, 2.5:1 and 3.0:1.			
129	16.04-90851	1	Bearing Assembly
NOTE: The following part is used on the 307Q—1.5:1, 2.0:1 and 327Q—1.5:1.			
130	16.04-90227	1	Retaining Ring
NOTE: The following part is used on the 307Q—2.5:1, 3.0:1 and 327Q—2.0:1 and 3.0:1.			
130	16.04-90852	1	Retaining Ring
131	16.51-00005	1	"O" Ring

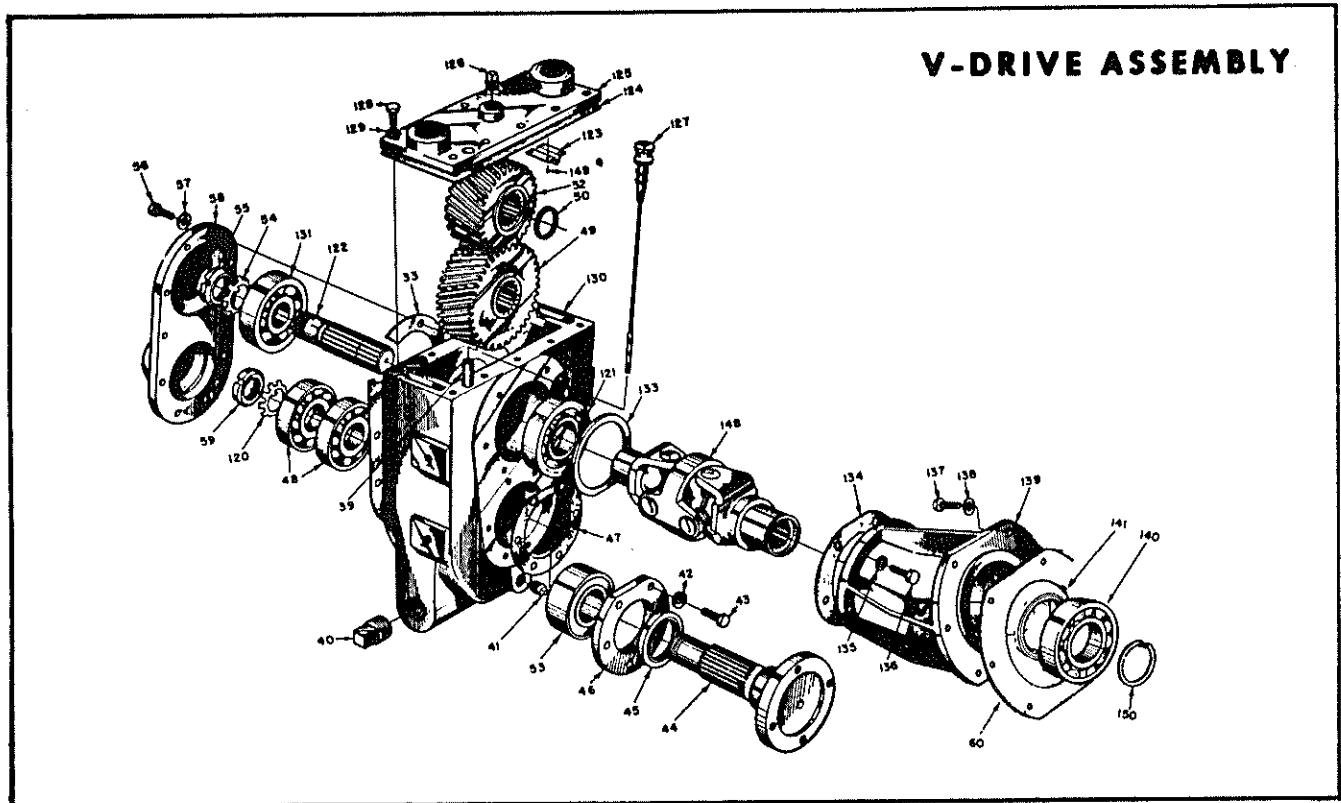

Code No.	Part No.	No. Req'd	Name
PV-300 PARAGON "V"-DRIVE			
29	16.04-90916	1	Angle Housing Yoke
30	16.04-90921	1	Welch Plug 1 3/8"
31	16.04-90918	2	Cross and Bearing Assembly
32	16.04-90920	1	"V"-Drive Housing Yoke
33	16.50-00156	1	"V"-Drive Housing to Side Cover Gasket
39	16.04-90729	1	Top Cover Dipstick Tube
40	16.04-90946	2	1" Cast Iron Plug
41	16.04-90436	1	Pipe Plug 3/8"—18 Oil Drain
42	16.04-90683	6	Lockwasher 3/8"
43	16.04-90922	6	Capscrew 3/8"—16 x 1"—Seal Cap to "V"—Drive Housing
44	16.04-90933	1	Coupling Gear Shaft
45	16.51-10025	1	Cap to Gear Shaft Oil Seal
46	16.04-90934	1	Seal Cap
47	16.50-00154	1	"V"-Drive Housing Seal Cap Gasket
48	16.90-00043	2	Gear Shaft Rear Bearing
49	16.04-90935	1	Driven Gear—Direct Drive

Chris-Craft®

Code No.	Part No.	No. Req'd	Name
<u>PV-300 PARAGON "V"-DRIVE</u>			
49	16.04-90936	1	Driven Gear—1.5:1
49	16.04-90937	1	Driven Gear—2.0:1
49	16.04-90938	1	Driven Gear—2.5:1
50	16.04-90925	1	Pinion Shaft Retaining Ring
52	16.04-90927	1	Pinion Gear—Direct Drive
52	16.04-90928	1	Pinion Gear—1.5:1
52	16.04-90929	1	Pinion Gear—2.0:1
52	16.04-90930	1	Pinion Gear—2.5:1
53	16.90-00042	1	Gear Shaft Forward Bearing
54	16.04-90931	1	Bearing Lockwasher
55	16.04-90932	1	Bearing Locknut
56	16.30-00122	10	Capscrew $\frac{3}{8}$ "—16 X 7/8"
57	16.04-90683	10	Lockwasher $\frac{3}{8}$ "
58	16.04-90940	1	"V"-Drive Housing Side Cover
59	16.04-90932	1	Bearing Locknut
60	16.50-00036	1	Reverse Gear Rear Housing to Angle Housing Gasket
120	16.04-90931	1	Bearing Lockwasher
121	16.90-00017	1	Pinion Gear Shaft Forward Bearing
122	16.04-90924	1	Pinion Shaft
123	16.04-90904	1	Top Cover Baffle
124	16.50-00155	1	"V"-Drive Housing to Top Cover Gasket
125	16.04-90939	1	"V"-Drive Housing Top Cover
126	16.04-90906	1	Pipe Plug—Breather Top Cover
127	16.04-90907	1	"V"-Drive Dipstick Assembly (includes seal)
	16.04-90793	2	Dipstick Seal

PV-300 PARAGON "V"-DRIVE

128	16.30-00122	10	Capscrew $\frac{3}{8}$ "—16 x $\frac{7}{8}$ "
129	16.04-90683	8	Top Cover Lockwasher $\frac{3}{8}$ "
	16.04-90446	2	Top Cover Seal Washer—2 Center Holes of Top Cover
130	16.04-90917	1	"V"-Drive Housing
131	16.90-00041	1	Pinion Gear Shaft Rear Bearing
133	16.04-90926	1	Pilot Spacer
134	16.50-00153	1	Angle Housing Rear Gasket
135	16.04-90683	6	Lockwasher $\frac{3}{8}$ "
136	16.04-90922	6	Capscrew $\frac{3}{8}$ "—16 x 1" Angle Housing to "V"-Drive Housing
137	16.30-00122	6	Capscrew $\frac{3}{8}$ "—16 x $\frac{7}{8}$ "
138	16.04-90446	6	Seal Washer
139	16.04-90915	1	Angle Housing
140	16.90-00002	1	Angle Housing Front Bearing
141	16.51-10024	1	Angle Housing Oil Seal
148	16.04-90919	1	Double Yoke
149	16.04-90905	4	Drive Screw

NOTE: The following part is used only after Paragon serial number 5M 2940.

150	16.04-90942	1	Retaining Yoke
-----	-------------	---	----------------

*Chris * Craft*

FOLLOWING PARTS USED ON NEW STYLE (6A)-(6B) SERIES V-DRIVE

Code No.	Part No.	No. Req'd.	Name
139A	16.04-91995	1	Angle Housing Assembly 20°
139B	16.04-91996	1	Angle Housing Assembly 25°
148A	16.04-91997	1	Universal Joint Assembly
	16.04-91998	1	Yoke, Angle Housing
60A	16.04-91999	1	Gasket, Angle Housing
58A	16.04-92000	1	Cover Assembly—Side
58B	16.04-92001	1	Cover — Side
30A	16.04-92002	1	Welch Plug
	16.04-92003	1	Plug Vent
130A	16.04-92004	1	Housing—V-Drive
122A	16.04-92005	1	Pinion Shaft
133A	16.04-92006	1	Spacer, Pilot
45A	16.04-92007	1	Seal
44A	16.04-92008	1	Shaft, Coupling
125A	16.04-92009	1	Cover
55A	16.04-92010	1	Nut, Bearing Lock Pinion
59A	16.04-92011	1	Nut, Bearing Coupling
127A	16.04-91978	1	Knob Dipstick
127B	16.04-91979	1	Rod Dipstick
43A	16.04-92012	6	12P Capscrew, Ferry Angle Housing
150A	16.04-92013	1	Ring—Retain V-Drive Housing
	16.04-92014	1	Pipe Plug—Brass ¼ - 18
152A	16.04-92015	1	Pinion Gear D.D.
52A	16.04-92016	1	Pinion Gear 1.5:1
52A	16.04-92017	1	Pinion Gear 2.0:1
52A	16.04-92018	1	Pinion Gear 2.6:1
124A	16.04-91983	1	Cover Gasket
121A	16.90-00017	2	Bearing—Pinion Gear Forward & Rear
			NAME PLATE—Use on 6A & 6B Series
	16.04-91980	2	Screw—Drive Name Plate
	16.04-91981	1	Plate—Name

*Chris * Craft*

SPLIT HOUSING V-DRIVE

Model	Ratio	Specification
PV31 R & L	1:1	Z-7867 R & L
PV32 R & L	1.5:1	Z-7868 R & L
PV33 R & L	2.0:1	Z-7869 R & L
PV34 R & L	2.5:1	Z-7870 R & L

Code No.	Chris*Craft IBM #	Quantity	Description
1	16.04-90536	6	Capscrew Hex. Hd.
2	16.04-90467	6	Seal Washer
3	16.51-10013	1	Oil Seal
4	16.04-91968	1	Front Plate
5	16.04-90622	1	Washer
6	16.04-90623	1	Bearing
7	16.04-90626	1	Pump Gear
8	16.04-40439	1	Pump Gear
9	16.04-91970	1	Pump Housing
10	16.04-90568	3	Capscrew Hex. Hd.
11	16.04-90567	3	Case Clip
12	16.04-90566	3	Shaft Locking Tab
13	16.04-90559	6	Shaft
14	16.04-90553	1	Bearing
15	16.04-90554	1	Case
16	16.04-90556	6	Pad
17	16.04-90557	(192)	Bearing 1 set
18	16.04-90555	3	Long Pinion
19	16.04-90558	3	Bearing Spacer
20	16.04-90562	3	Short Pinion
21	16.04-90557		Refer to Code No. 17
22	16.04-90556		Refer to Code No. 16
23	16.04-90565	3	Short Pinion Spacer
24	16.04-90563	(192)	Bearing 1 set
25	16.04-90561	1	Engine Gear
26	16.04-90564	3	Bearing Spacer
27	16.04-90563		Refer to Code No. 24
28	16.04-90560	2	Bearing
29	16.04-90569	1	Washer
30	16.04-90842	1	Propeller Gear
31	16.04-91965	1	Washer
32	16.04-90575	6	Plate
33	16.04-90574	7	Plate
34	16.04-90804	1	Retaining Ring

*Chris*Craft*®

Code No.	Chris*Craft IBM #	Quantity	Description
35	16.04-90803	1	Retainer
36	16.04-90802	1	Spring
37	16.51-00006	1	"O" Ring
38	16.51-00005	1	"O" Ring
39	16.04-90801	1	Forward Piston
40	16.04-90395	2	Lockscrew
41	16.04-90396	2	Clip
42	16.04-90800	1	Screw Collar
43	16.04-90577	1	Bearing
44	16.04-90397	2	Ring
45	16.04-90633	1	Capscrew Hex. Hd.
46	16.04-90666	1	Lockwasher
47	16.04-90746	1	Washer
48	16.04-90730	1	Lever
49	16.04-90733	1	Bushing
50	16.04-90732	1	Pawl
51	16.04-90731	3	Pin
52	16.51-00007	1	"O" Ring
53	16.04-91973	1	Valve
54	16.04-90604	1	Retaining Ring
55	16.04-91974	1	Detent Plug
56	16.04-92042	1	Cover
57	16.04-90731		Refer to Code No. 51
58	16.51-00011	1	"O" Ring
59	16.04-90817	1	Reverse Piston Assembly
60	16.04	1	Plate
61	16.51-00012	1	"O" Ring
62	16.04-90820	2	Pin
63	16.04-90821	4	Retaining Ring
64	16.04-90820		Refer to Code No. 62
65	16.04-90819	2	Lever
66	16.04-90822	1	Roll
67	16.04-90819		Refer to Code No. 65
68	16.04-90821		Refer to Code No. 63
69	16.04-92043	1	90° Street Elbow
70	16.04-92044	1	Hose Assembly
71	16.04-92045	1	90° Elbow
72	16.04-91983	1	Cover Gasket
73	16.04-90807	1	Tube
74	16.04-90813	1	Breather
75	16.04-90812	6	Capscrew External Socket
76	16.04-90412	1	Pin
77	16.04-90825	1	Pipe Plug Sq. Hd.
78	16.04-90826	1	Spring

*Chris*Craft*®

Code No.	Chris*Craft IBM #	Quantity	Description
79	16.04-90411	1	Relief Valve Plug
80	16.04-80410	1	Relief Valve Spring
81	16.04-90824	1	Retaining Ring
82	16.51-00009	1	"O" Ring
83	16.04-90823	1	Housing
84	16.04-90878	1	Screw
85	16.04-92035	3(MAX)	Washer
86	16.04-90729	1	Tube
87	16.04-90388	1	Pump Key
88	16.04-90828	1	Dipstick Assembly
89	16.50-00036	1	Rear Gasket
90	16.04-90810	1	Pin
91	16.04-90584	1	Baffle
92	16.04-90633	2	Capscrew Fl. Hd. Socket
93	16.04-91977	1	Housing
94	16.04-92014	1	Pipe Plug Sq. Hd.
95	16.04-90581	1	Tube
96	16.04-90808	1	Reverse Band Assembly
97	16.50-00173	1	Front Plate Gasket
98	16.04-91982	8	Capscrew Hex. Socket
99	16.04-92046	1	Universal Joint Assembly
100	16.04-92047	1	Angle Housing Gasket
101	16.04-92048	6	Capscrew Hex. Hd.
103	16.04-92049	1	Angle Housing
104	16.04-92050	1	Bearing
105	16.04-92051	1	Bearing
106	16.04-92052	1	Race
107	16.04-90594	6	Capscrew Hex. Hd.
109	16.04-92053	1	Nut
110	16.04-92054	2	Bearing
111	16.04-92055	1	Pinion 1:1 Only
111	16.04-92056	1	Pinion 1.5:1 Only
111	16.04-92057	1	Pinion 2.0:1 Only
111	16.04-92058	1	Pinion 2.5:1 Only
112	16.04-92054		Refer to Code No. 110
113	16.04-92059	1	Spacer
114	16.04-90911	1	Pipe Plug Sq. Hd.
115	16.04-92050	2	Bearing
116	16.04-92060		Refer to Code No. 115
117	16.04-92061	1	Gear 1:1 Only
117	16.04-92062	1	Gear 1.5:1 Only
117	16.04-92063	1	Gear 2.0:1 Only
117	16.04-92064	1	Gear 2.5:1 Only
118	16.04-92065	1	Bearing
119	16.04-92066	1	Retaining Ring
120	16.04-92067	1	Oil Seal
121	16.04-92068	1	Coupling
122	16.04-92069	1	"O" Ring
123	16.04-92011	1	Nut
124	16.04-92070	1	Housing Assembly

*Chris*Craft*®

SERVICE # 124 AS AN ASSEMBLY ONLY
CONSISTING OF:

A	1/2-13 X 3-1/2	3	Capscrew Hex. Hd.
B	1/2-13 X 5"	3	Capscrew Hex. Hd.
C	1/2-13	6	Hex Nut
D	1/2	5	Lockwasher
E	1/2	2	Washer
F	X-12771	2	Alignment Pin
G	L. H.	1	Housing
H	R. H.	1	Housing

Chris-Craft

GEAR CASE ASSEMBLY

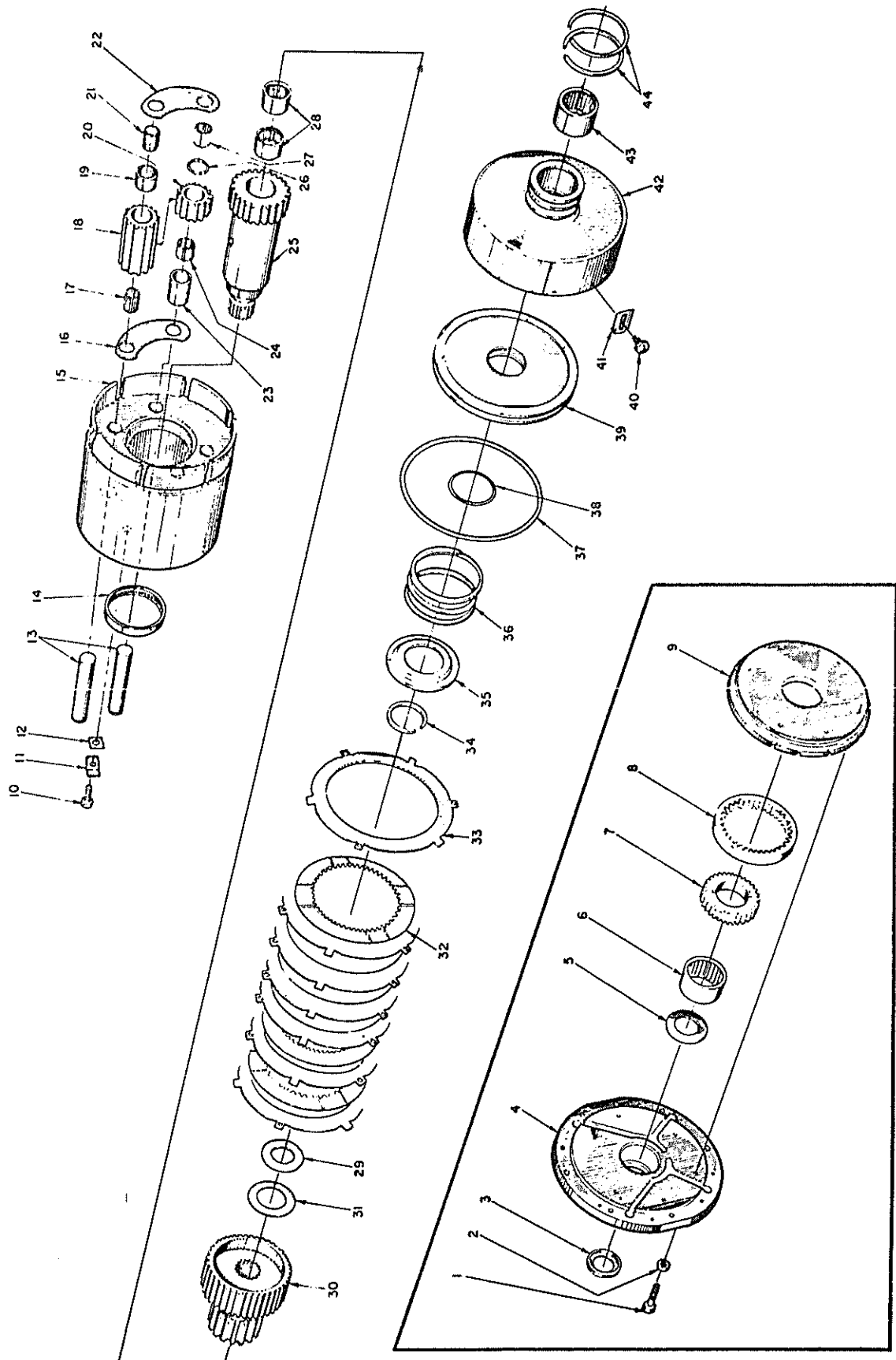

V-DRIVE ASSEMBLY - STANDARD ROTATION
(2 Gear Set)

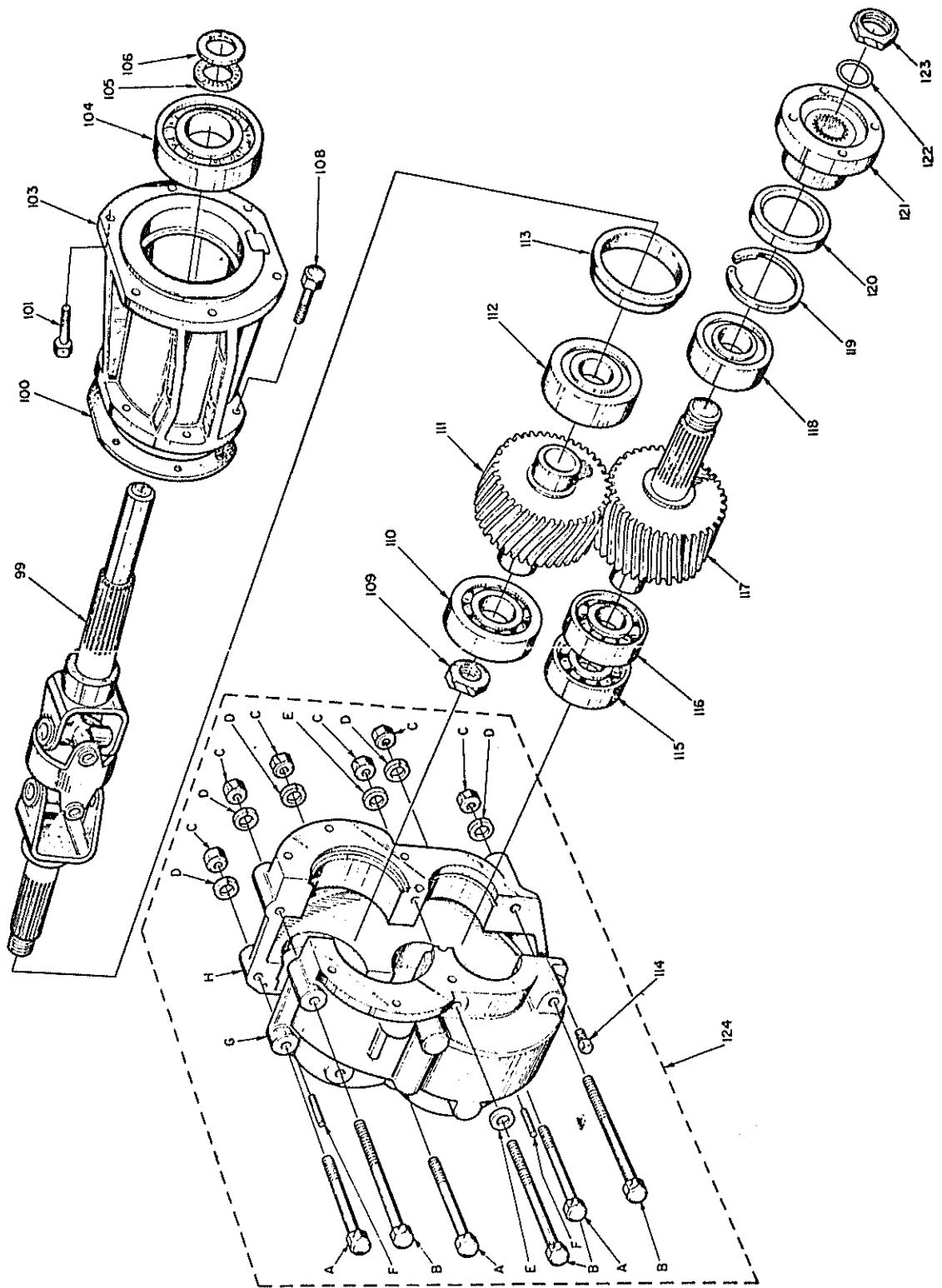

PV-300 COMPLETE ASSEMBLY

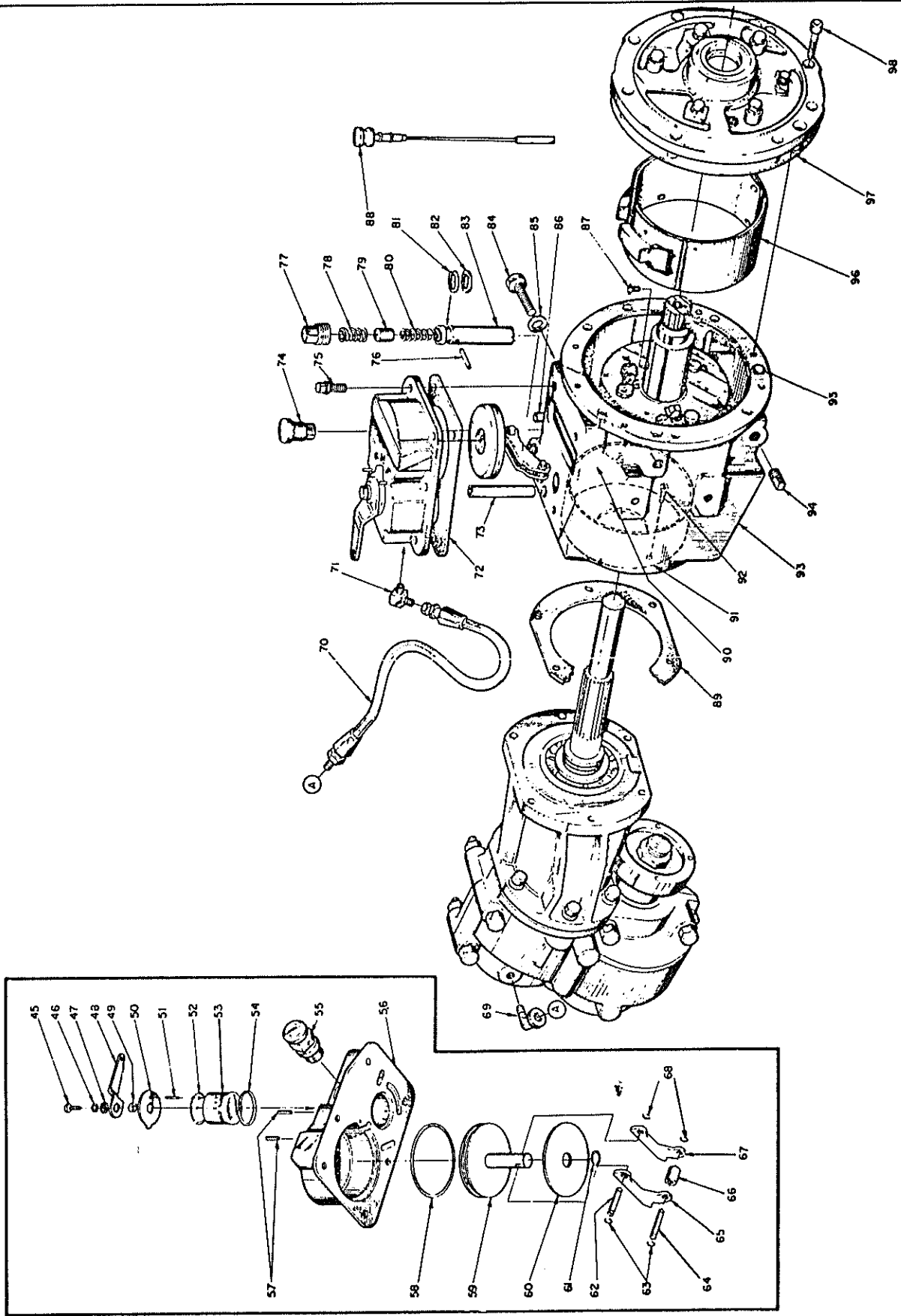

Chris-Craft®

